

# CATALOGO DE PARTES

*ELEVADOR  
ELECTRIC* | E 18-30



**MICHIGAN®**



# Contenido

Item	Code	Name	Models	page
00	Fig . 1	Vista general	AB	1
01	2 Fig.2	Batería	AB	2
02	3 Fig.3	Sistema dirección	AB	3
	4 Fig.4	Eje y cuerpo de transmisión	AB	4
	5 Fig.5	Conjunto del freno	AB	6
03	6 Fig.6	Sistema de dirección	AB	7
	7 Fig.7	Eje de dirección	AB	8
	8 Fig.8	Cilindro de dirección	AB	10
	9 Fig.9	Columna de dirección	AB	11
06	10 Fig . 10	Conjunto de freno	AB	12
07	11 Fig . 11	Freno de estacionamiento	AB	14
08	12 Fig . 12	Cuadro	AB	16
09	13 Fig . 13	Sistema de piso	AB	17
10	14 F ig . 14	Mástil (normal)	AB	21
	15 F ig . 15	Soporte de horquilla y elevación (mástil normal)	AB	24
	16 F ig . 16	Cilindro de elevación (normal)	AB	26
	17 F ig . 17	Cilindro de inclinación (normal)	AB	29
	18 F ig . 18	Sistema de tubería de desplazamiento lateral (normal)	AB	32
	19 F ig . 19	Sistema de tubo de elevación (mástil normal)	AB	34
11	20 F ig .20	Control multiválvulas	AB	35
12	21 F ig .21	Sistema hidráulico	AB	37



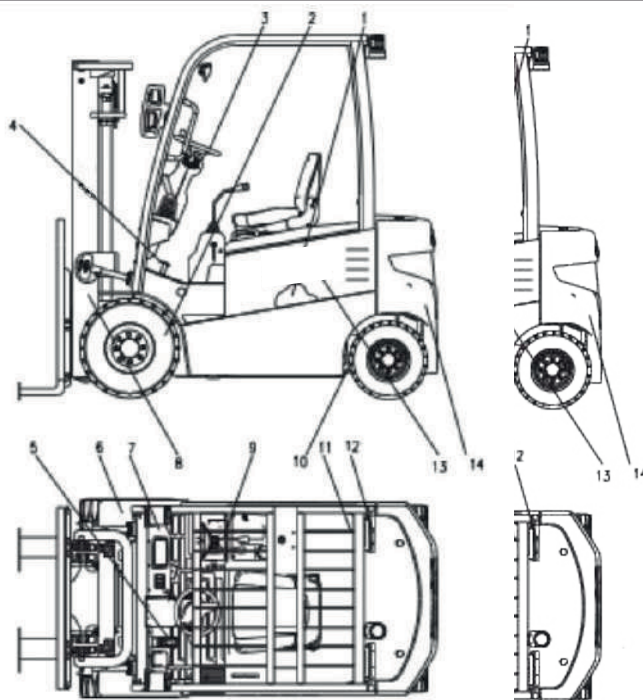

Item No	Code	Part No	Description	Q'ty	Remark
1	60400002788	E0015T.01	Power system	1	
2	30002910270	E0015T.02	Drive system	1	
3	30003910147	E0015T.03	Steering system	1	
4	30006910161	E0015T.06	Service brake system	1	
5	30007910121	E0025T.07	Parking brake system	1	
6	30008910097	E0015T.08	Frame system	1	
7	30009910033	E0015T.09	Mantle system	1	
8	30080910035	E0015T.10	Standard mast system	1	
9	30011910123	E0025T.11	Multiway control system	1	
10	30012910057	E0015T.12	Hydraulic system	1	A
	30012910066	E0018T.12	Hydraulic system	1	B
11	30014910270	E0015T.14	Overhead guard system	1	
12	30015910097	E0015T.15	Electrical system	1	
13	30016910015	E0015T.16	Label system	1	A
	30016910019	E0018T.16	Label system	1	B
14	30017910188	E0015T.17	Counter weight system	1	A
	30017910194	E0018T.17	Counter weight system	1	B

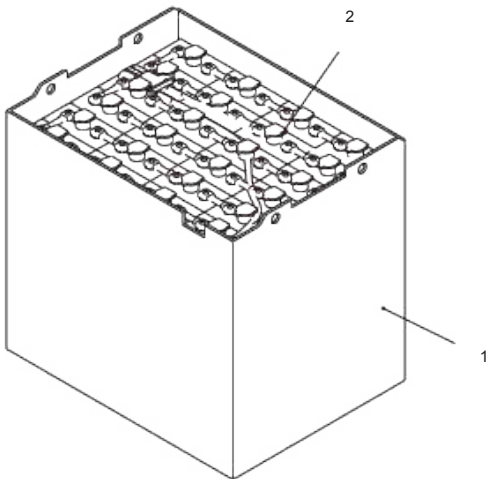

Item No	Code	Part No	Description	Q'ty	Remark
1	60400002789	E0015T.01.01	Battery box weldment	1	
2	60400002784	4PZS480	Single battery	24	

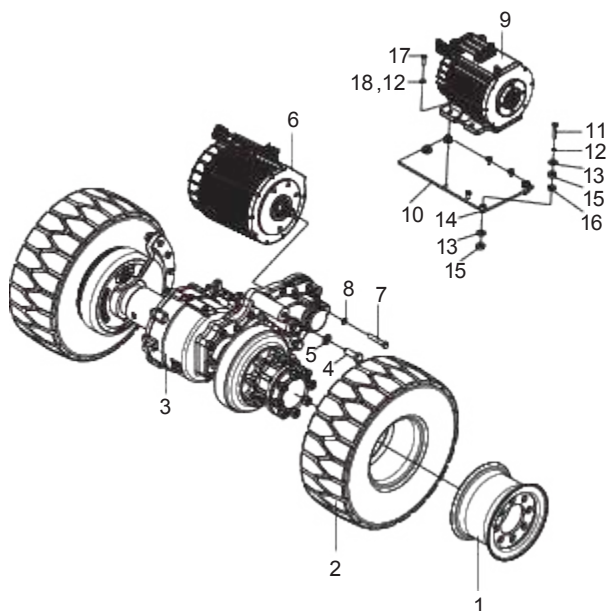

Item No	Code	Part No	Description	Q'ty	Remark
1A	30002024327	E0015T.2.01	Drive wheel assy.	2	1-2
1	60205000020	GB/T2982	Tire assy.	2	
2	60200000801	E0015T.02.01.01	Tire rim assy.	2	
3	60200000802	E0015T.02.02	Drvide axle assy.	1	
4	51207151714	GB/T5786	Bolt M12×1.5×55	8	
5	51421150115	GB/T97.1	Washer 20	8	
6	60200000803	E0015T.02.03	Traction motor assy.	1	JXQ-8. 2-W
7	51207122214	GB/T5786	Bolt M14×1.5×80	5	
8	51401120107	GB/T93	Washer 14	5	
9	60200000804	E0015T.02.04	Pump motor assy.	1	JXQD-10. 6-W
10	30002105304	E0025T.02-001	Mounting plate	1	
11	51204101614	GB/T5783	Bolt M10×50	4	
12	51401100107	GB/T93	Washer 10	8	
13	51420100121	GB/T96.1	Washer 10	4	
14	30002135107	E0025T.02-002	Shaft sleeve	4	
15	60700002706	E0025T.02-003	Rubber gasket	8	
16	51420130121	GB/T96.1	Washer 16	8	
17	51207105214	GB/T5786	Bolt M10×1.25×30	4	
18	51421100115	GB/T97.1	Washer 10	4	

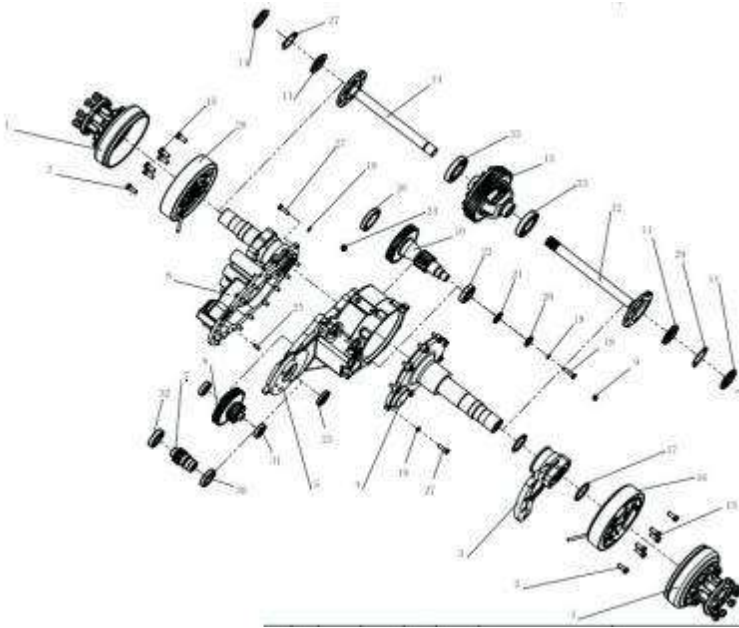

Item No	Code	Part No	Description	Q'ty	Remark
A		E0015T.02.02	Axle & transmission body	1	
1		QX15B-10000	Stop bolt	2	
2		2400007-HY430	Aticulated bolt	4	
3		QX15B-90002	Sector plate	1	
4		QX15B-30000	Axle body element(R)	1	
5		QX25A-10001	Transmission	1	
6		QX15B-41000	Shaft II gear	1	
7		QX25A-60001	Shaft I gear	1	
8		QX15B-20000	Axle body element (L)	1	
9		QC30A-91000	Vent plug	1	
10		QX15B-90004	Gear	1	
11		QX15A-90003	Small round nut	1	
12		QX15B-90003	Axle shaft(R)	1	
13		QX25A-40000	Differential assy.	1	
14		QX15B-90001	O ring	1	
15		GB/T5786-2016	Hexagon head bolt	8	
16		254048-0Y05R	Brake assy.(R)	1	
17		GB/T3452.1-2005	O ring	2	



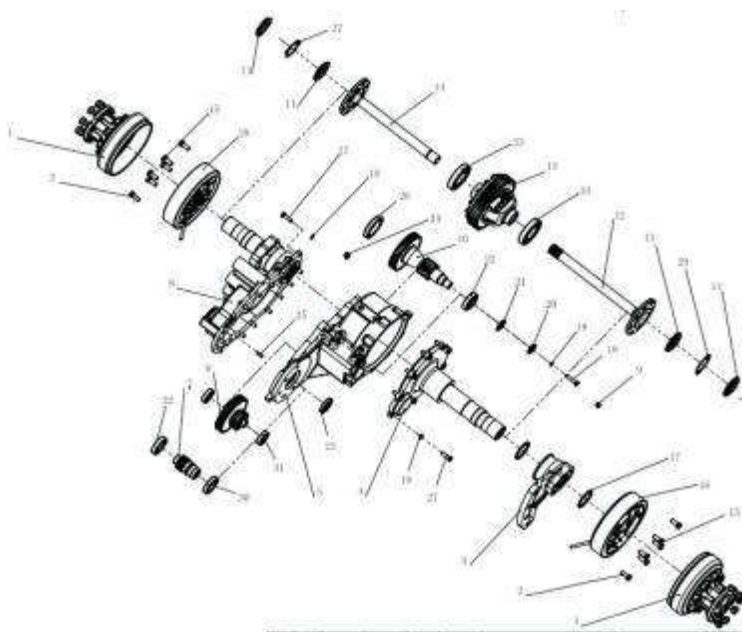

Item No	Code	Part No	Description	Q'ty	Remark
18		GB/T5786-2016	Hexagon head bolt	1	M12 X 1.5 X 50
19		GB/T93-1987	Spring washer	25	12
20		QX15A-90004	Lockout nut	1	M30 X 1.5 X 20
21		QX25A-90003	Plane washer	1	31 X 52 X 5
22		GB/T297-2015	Tapered roller bearing	1	32208
23		GB/T13871.1-2007	lip seal ring	1	FB48 X 70 X 12 ( NAK)
24		JB/ZQ4446-2006	Plug screw	3	R1/2
25		GB/T119.1-2000	Cylindrical pin	1	10m6 X 26
26		GB/T297-2015	Tapered roller bearing	1	32915
27		GB/T5786-2016	Hexagon head bolt	24	M12 X 1.5 X 40
28		254048-0Y04L	Brake assy.(L)	1	L474Z18
29		GB/T858-1988	Round stop washer	2	65
30		GB/T276-2013	Deep groove ball bearing	1	6010 P6
31		GB/T276-2013	Deep groove ball bearing	2	6206
32		GB/T276-2013	Deep groove ball bearing	1	6208 P6
33		GB/T276-2013	Deep groove ball bearing	2	6213 G3

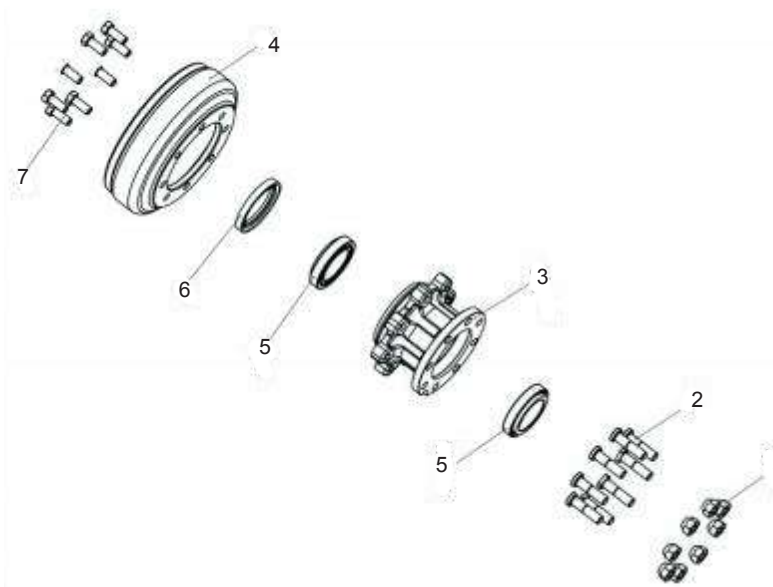

Item No	Code	Part No	Description	Q'ty	Remark
A		QX15B-10000	Brake hub element	1	
1		QX15A-20004	Wheel hub nut	8	M16 X 1.5 X 20
2		QX15A-20005	Wheel hub bolt	8	M16 X 1.5 X 60
3		QZ15B-10001	Wheel hub	1	
4		QX15A-20002	Brake hub	1	3T-A
5		GB/T297-215	Tapered roller bearing	2	32013
6		GB/T13871.1-2007	Lip seal ring	1	FB75 X 105 X 12
7		GB/T5786-2016	Hexagon head bolt	8	M14 X 1.5 X 35

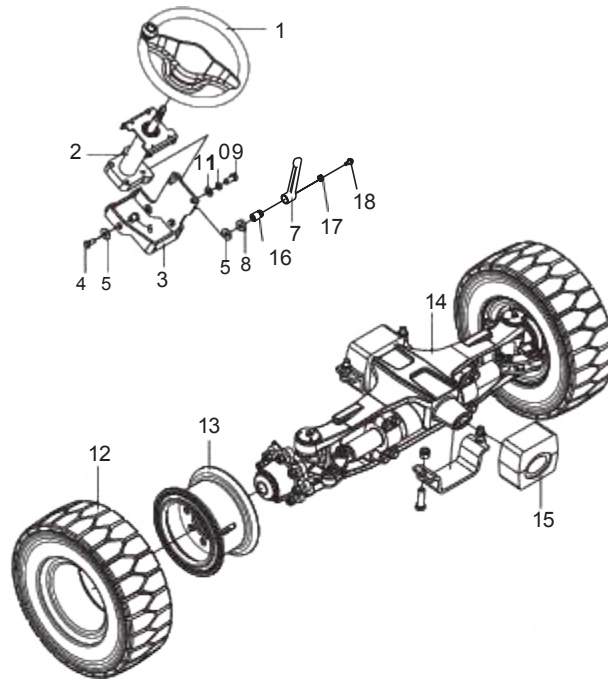

Item No	Code	Part No	Description	Q'ty	Remark
1	60305000040	E0016B.03.09	Steering wheel assy.	1	
2	60200000791	E0025T.03.01	Steering column assy.	1	
3	30003018125	E0025T.03.02	Bracket weldment	1	
4	51207105014	GB/T5786	Bolt M10×1.25×25	2	
5	51420100121	GB/T96.1	Washer 10	2	
6	30003135116	E0025T.03-001	Shaft sleeve	2	
7	60700002275	E0035DTN.03.01-002	Handle	1	
8	60700002704	E0025T.03-002	Friction rubber gasket	1	
9	51207115114	GB/T5786	Bolt M12×1.25×25	2	
10	51401110107	GB/T93	Washer 12	2	
11	51421110115	GB/T97.1	Washer 12	2	
12	60200000613	E0015TBII.03.02	Tire assy.	2	
13	60200000805	E0015T.03.01	Rim assy.	2	
14	60200000806	E0015T.03.02	Steering axle assy.	1	
15	30003109004	30D-0311001	Rubber gasket	2	
16	60700002270	E0035DTN.03.01-003	Screw	1	
17	60700002249	E0035DTN.03.01-004	Spring	1	
18	60700002784	E0025T.03.03-003	Stud	1	

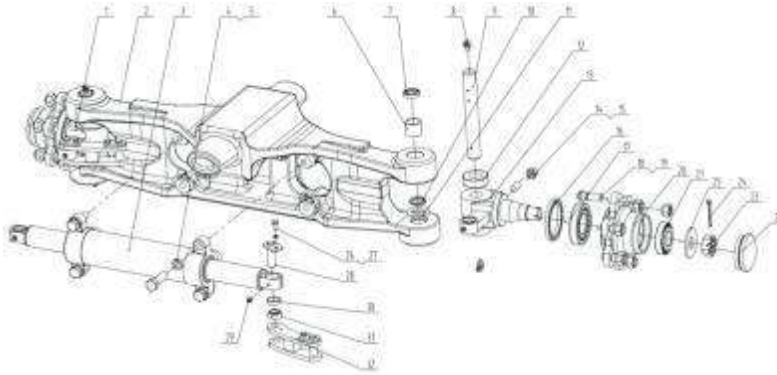

Item No	Code	Part No	Description	Q'ty	Remark
A		A6S54-30001WB	Steering axle assy.	1	
1		A6S54-30401	Left steering knuckle	1	
2		A6S54-32001C	Steering axle body	1	QT450- 12
3		A6S54-30201	Steering cylinder	1	
4		B0330-14050B	Bolt M14×55	4	45
5		B5050-00014B	Spring washer	4	65Mn
6		Z-942/25	Needle bearing	4	
7		24234-32231	Oil seal	4	
8		Q701B45	Seal ring	4	
9		24234-32181A	Lubricant nipple	2	20CrMo
10		24234-32241	O ring	2	1-3
11		20114-30091	Main pin cover	4	08AL
12		Z-198905	Main pin	2	
13		A6S54-30301	Right steering knuckle assy.	1	
14		B8050-1230B	Fixed screw	2	35
15		B4133-00012B	Nut M12	2	45
16		22574-32102	Oil sea	2	
17		Z-30208	Tapered roller bearing	2	

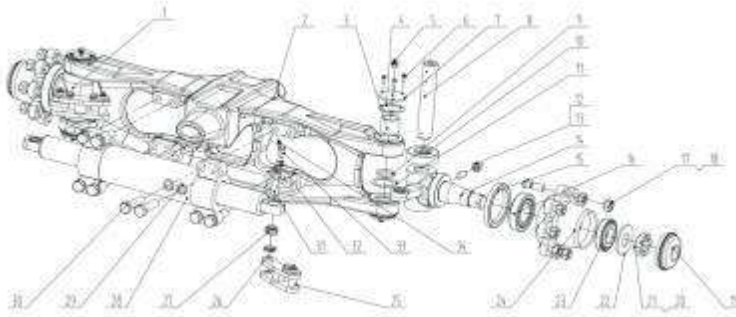

Item No	Code	Part No	Description	Q'ty	Remark
18		23654-32041B	Hub bolt	16	35CrMo
19		23654-32051B	Hub bolt	16	45
20		24234-32221Z	Steering hub	2	QT450- 10
21		Z-30206	Tapered roller bearing	2	
22		22194-32361N	Hub cap	2	08AL
23		24234-32311	Castle nut	2	Q235A
24		B3010-05045	Cotter pin	2	Q235A
25		G15X4-32111	Washer	2	Q235A
26		B0330-06012B	Bolt	4	45
27		B505-0006B	Spring washer	4	65Mn
28		H12C4-30501B	Lock pin	4	
29		Q700B06	Straight lubricant nipple	4	
30		H12C4-32101	Bushing	6	Q235A
31		Z-GE15ES	Radial joint bearing	4	
32		X18E4-32061AB	Linkage	2	

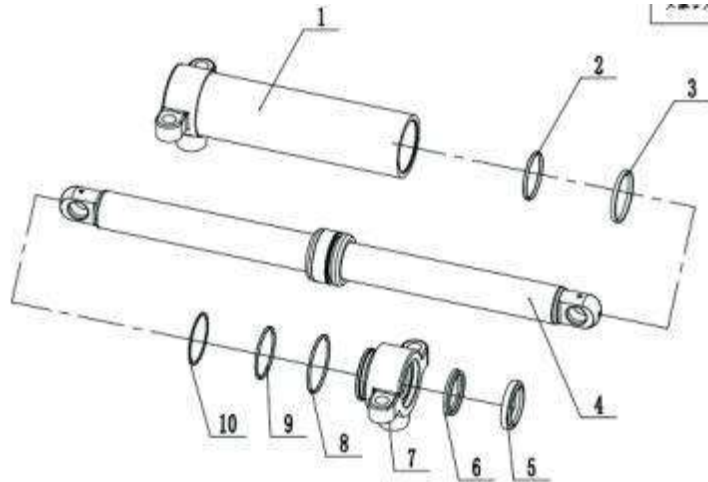

Item No	Code	Part No	Description	Q'ty	Remark
A		A6S54-30201	Steering cylinder assy.	1	
1		A6S54-32201	Cylinder body	1	
2		Z6053-04753	O ring	1	
3		A10C4-52041	Pivot ring	2	
4		A6S54-30202	Piston body	2	
5		23650-83581	D u s t r i n g	2	
6		23918-52161	U shape ring	2	
7		G15X4-32201	Cylinder cover	2	
8		C03107	O seal ring	2	
9		Z6053-05002	O seal ring	2	
10		G15X4-33181	Snap ring	2	

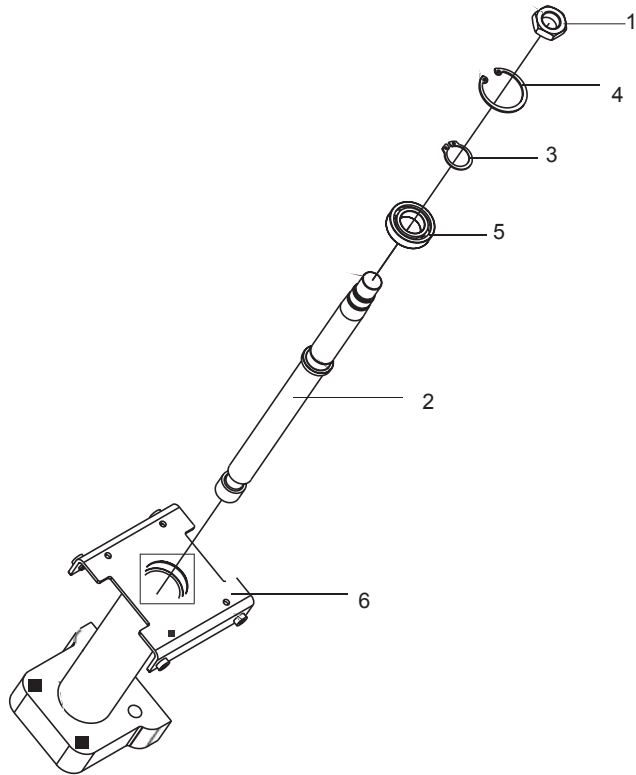

Item No	Code	Part No	Description	Q'ty	Remark
1	51312000719	GB/T6173	Nut M16×1.5	1	
2	60200000793	E0025T.03.01-001	Rotary shaft	1	
3	51453200107	GB/T894.1	Snap ring 20	1	
4	51451330107	GB/T893.1	Snap ring 37	1	
5	52198010201	GB/T276	Bearing 61904Right arrester	1	
6	60700002708	E0025T.03.01.01	Bracket	1	

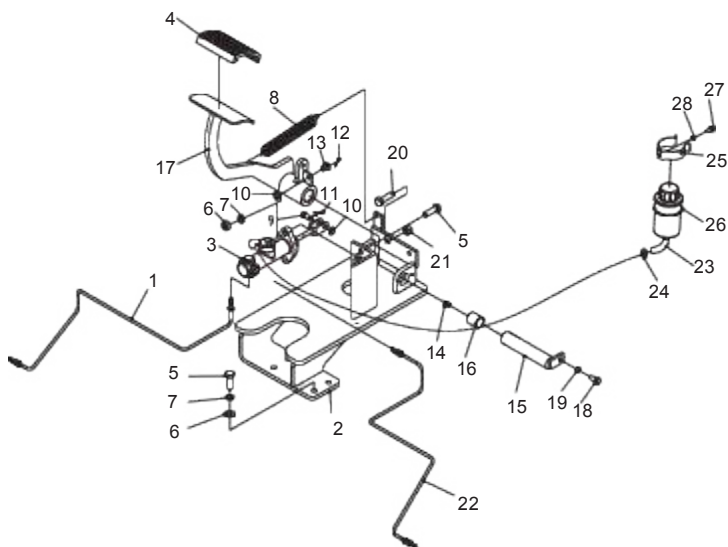

Item No	Code	Part No	Description	Q'ty	Remark
1	60700002947	E0015T.06.01	Steel tube assy.	1	
2	60700003315	E0015T.06.02.02	Bracket weldment	1	
3	30006043201	30D-0631300	Brake master cylinder	1	
4	60700002788	E0025T.06.02-001	Pedal gasket	1	
5	51204101214	GB/T5783	Bolt M10×30	2	
6	51307001019	GB/T6170	Nut M10	2	
7	51401100107	GB/T93	Waher 10	2	
8	60700002789	E0025T.06.02-002	Spring	1	
9	51512071001	GB/T91	Pin 2.5×20	1	
10	51421090115	GB/T97.1	Washer 8	2	
11	51511051202	GB/T882	Pin B8×28	1	
12	51512061001	GB/T91	Pin 2×20	1	
13	30006117300	E0030DIII.06.01-003	Damping	1	
14	56201000301	JB/T7940.1	cushion Oil cup	1	
15	60700002791	E0025T.06.02.03	M 10 × 1 Pin shaft	1	
16	52011000402	GB/T12613.1	weldment Slide	2	
17	60800000402	E0015T.06.02.01	bearing 25×28×25	1	
18	51204090914	GB/T5783	Pedal weldment	1	



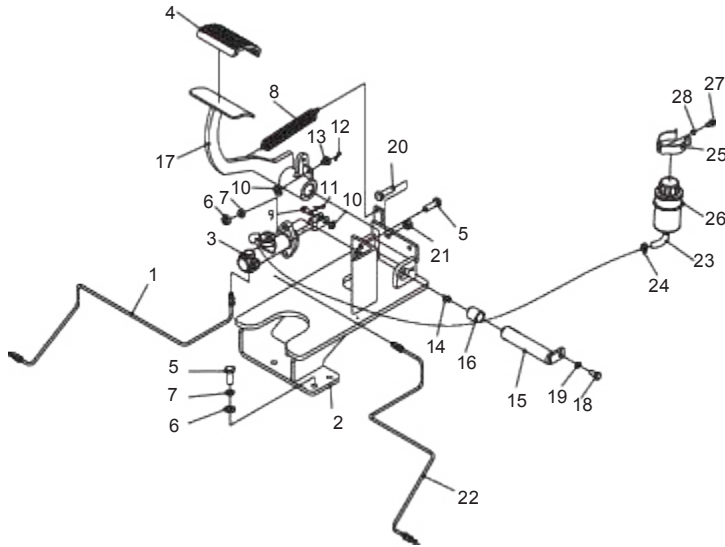

Item No	Code	Part No	Description	Q'ty	Remark
19	51401090107	GB/T93	Waher 8	1	
20	51207105314	GB/T5786	Bolt M10×1.25×35	1	
21	51309000319	GB/T6171	Nut M10×1.25	1	
22	51204101214	GB/T5783	Bolt M10×30	4	
23	60700002948	GB/T93	Washer 10	4	
24	30006112202	GB/T97.1	W a s h e r 1 0	4	
25	60700002779	E0015T.06.03	Steel tube assy.	1	
26	30012187927	E0025TBIII.06-001	Plastic tube	1	
27	56171000101	JB/T8870	Hoop	2	
28	30006109601	30D-0601001	Clamp	1	
29	60980001075	30D-0600001	Brake fluid oil cup	1	
30	51158190304	GB/T818	Screw M6×12	1	
31	51401080107	GB/T93	Washer 6	1	

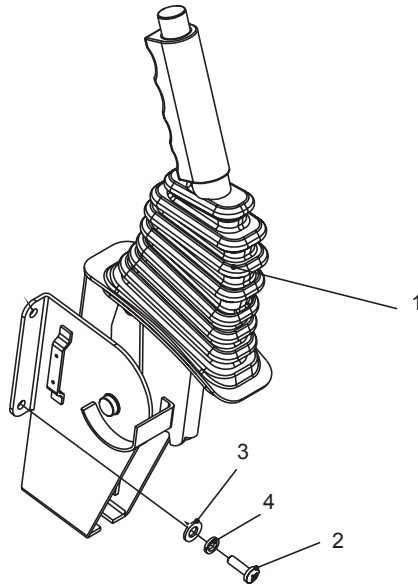

Item No	Code	Part No	Description	Q'ty	Remark
1	60800000396	E0025T.07.01	Parking brake control	1	
2	51158190604	GB/T818	Bolt M10×1.25×40	4	
3	51421080115	GB/T93	Washer 10	4	
4	51401080107	GB/T97.1	Washer 10	4	

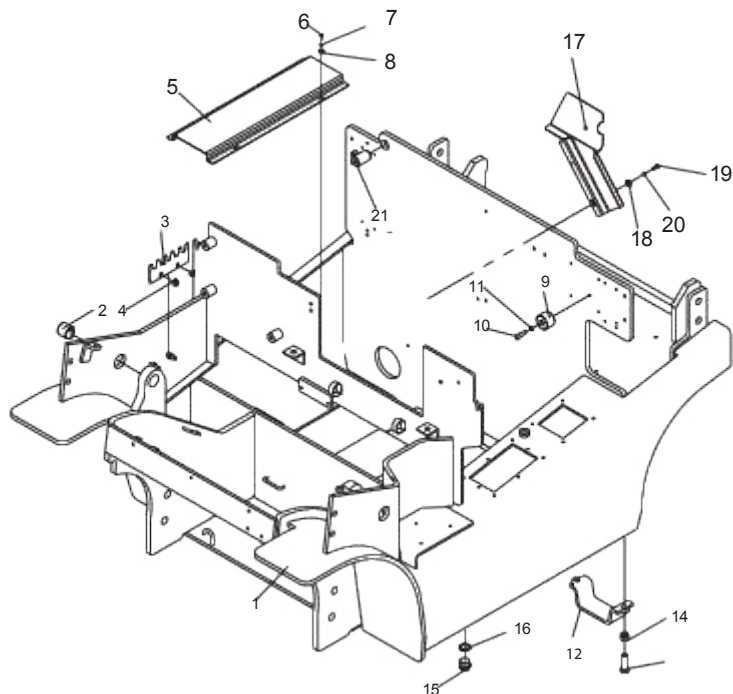

Item No	Code	Part No	Description	Q'ty	Remark
1	30008050229	E0015T.08.01	Frame weldment	1	
2	52001000302	GB/T12949	Slide bearing 30×34×30	2	
3	30008114986	E0025T.08-002	Bracket	1	
4	51307000919	GB/T6170	Nut M8	4	
5	30008107343	E0015T.08-001	Cover plate	1	
6	51204080814	GB/T5783	Bolt M6×12	4	
7	51420080121	GB/T96.1	Washer 6	4	
8	51401080107	GB/T93	Washer 6	4	
9	60700002642	E0025T.08-004	Sheath	2	
10	51139220405	GB/T70.1	Screw M10×30	2	
11	51401100107	GB/T93	Washer 10	2	
12	30008105301	30D-0800024	Mounting plate	2	
13	51204135014	GB/T5783	Bolt M16×55	4	
14	51341000919	GB/T889.1	Nut M16	4	
15	56302001202	JB/ZQ4444	Screw plug M30×1.5	1	
16	56147011701	JB/T982	Combination washer 30	1	
17	30008046523	E0015T.08.02	Cover plate weldment	1	
18	51420090121	GB/T96.1	Washer 8	2	

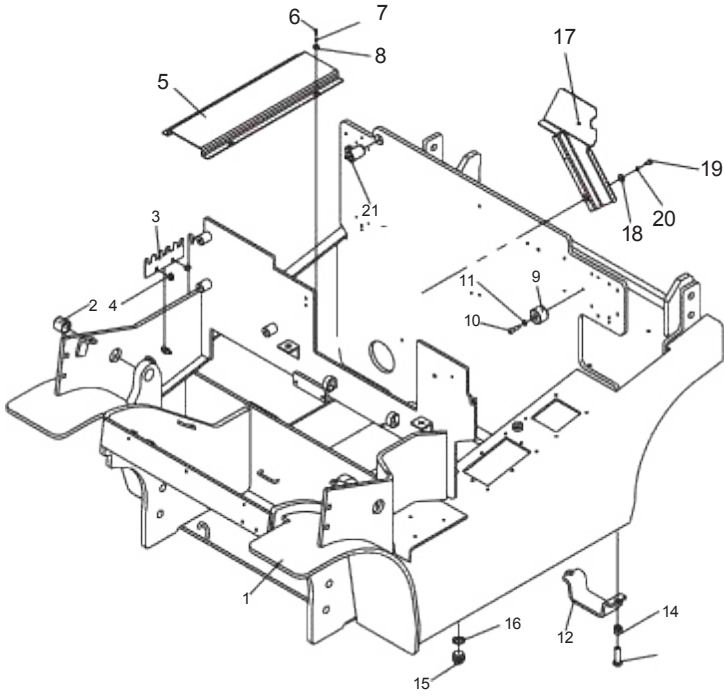

Item No	Code	Part No	Description	Q'ty	Remark
19	51204090914	GB/T5783	Bolt M8×16	2	
20	51401090107	GB/T93	Washer 8	2	
21	30008025000	E0025T.08.02	Pin shaft weldment	1	

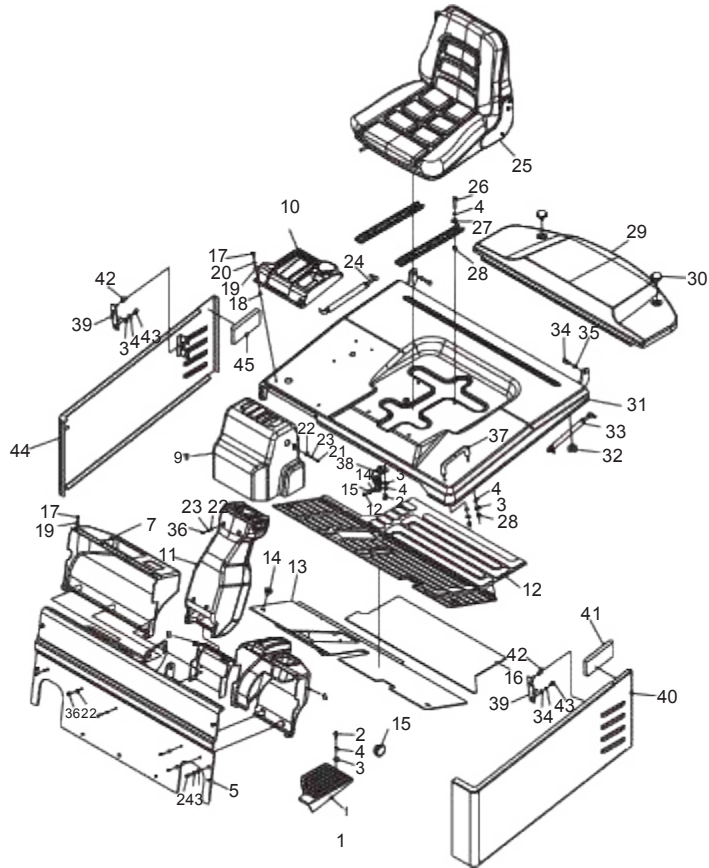

Item No	Code	Part No	Description	Q'ty	Remark
1	60700002919	E0015T.09-001	Pedal body	1	
2	51204091014	GB/T5783	Bolt M8×20	12	
3	51421090115	GB/T97.1	Washer 8	21	
4	51401090107	GB/T93	Washer 8	24	
5	30009047401	E0015T.09.01	Instrument carrier assy.	1	
6	60700002915	E0015T.09.07.01	Hood assy.	1	
7	60700002912	E0015T.09.07-001	Hood	1	
8	60700002737	E0025T.09.07-002	Hood	1	
9	60700002748	E0025T.09.07.02	Hood assy.	1	
10	60700002738	E0025T.09.07-003	Hood	1	
11	60700002749	E0025T.09.07.03	Hood assy.	1	
12	60700002920	E0015T.09-002	Rubber gasket	1	
13	30009042215	E0015T.09.03	Bottom plate weldment	1	
14	60700002786	E0025T.09-010	Screw	2	

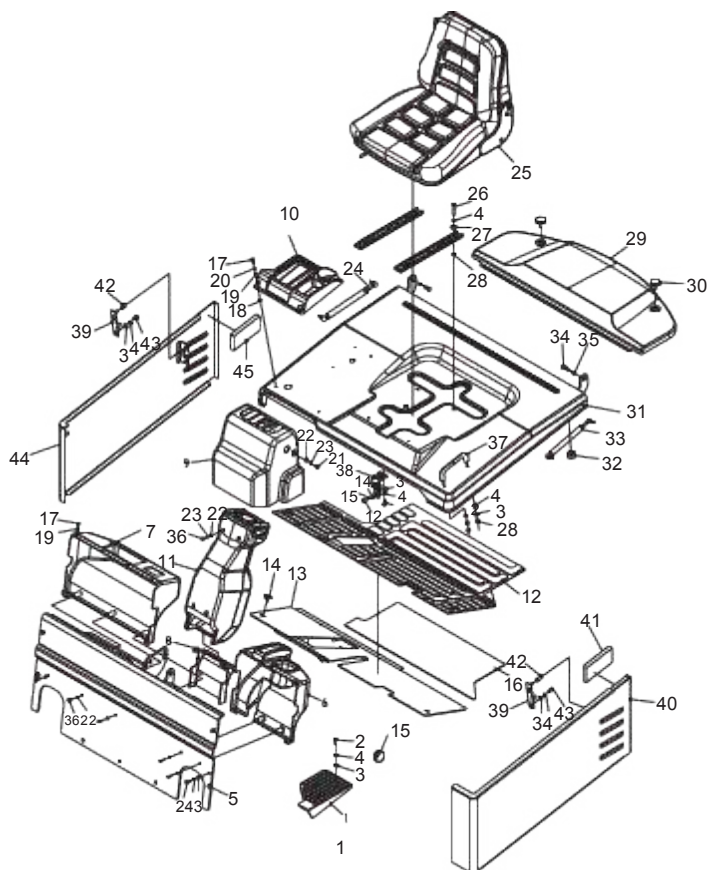

Item No	Code	Part No	Description	Q'ty	Remark
15	60700002772	E0025T.09-001	Rubber cover	2	
16	30009042214	E0015T.09.02	Bottom plate weldment	1	
17	51158190504	GB/T818	Screw M6×16	12	
18	51307000819	GB/T6170	Nut M6	3	
19	51421080115	GB/T97.1	Washer 6	12	
20	51401080107	GB/T93	Washer 6	5	
21	51158170704	GB/T818	Screw M5×20	3	
22	51421070115	GB/T97.1	Washer 5	18	
23	51401070107	GB/T93	Washer 5	11	
24	60700003314	E0015T.09-004	Air spring assy.	1	
25	60920010019	20B-0911000	Seat assy.	1	
26	51204091514	GB/T5783	Bolt M8×45	4	
27	51420090121	GB/T96.1	Washer 8	4	
28	51307000919	GB/T6170	Nut M8	6	

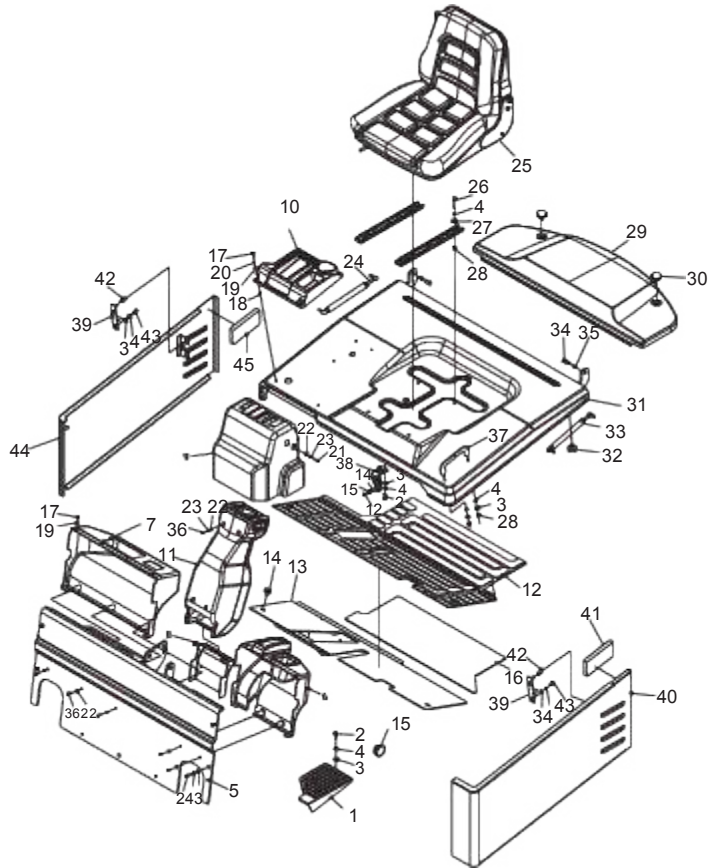

Item No	Code	Part No	Description	Q'ty	Remark
29	30009107390	E0015T.09-003	Cover plate	1	
30	60700002761	E0025T.09-005	Screw	2	
31	60700002911	E0015T.09.06	Cover assy.	1	
32	60900006910	E0025T.09-011	Rubber gasket	4	
33	60700002768	E0025T.09-007	Air spring	1	
34	60700002762	E0025T.09-008	Screw	2	
35	52011003801	GB/T12613.1	Slide bearing	2	
36	51158170604	GB/T818	Screw	15	
37	33009168900	E0045Q.09-005	Handle	1	
38	60900001288	E0075DTG.08.04	Spring clamp	1	
39	30009018123	E0025T.09.04.01	Bracket weldment	3	
40	30009045711	E0015T.09.04.01	Side board weldment	1	
41	60700002763	E0025T.09.04-001	Seal stripe	1	
42	60700002773	E0025T.09.04-002	Rubber sheath	7	

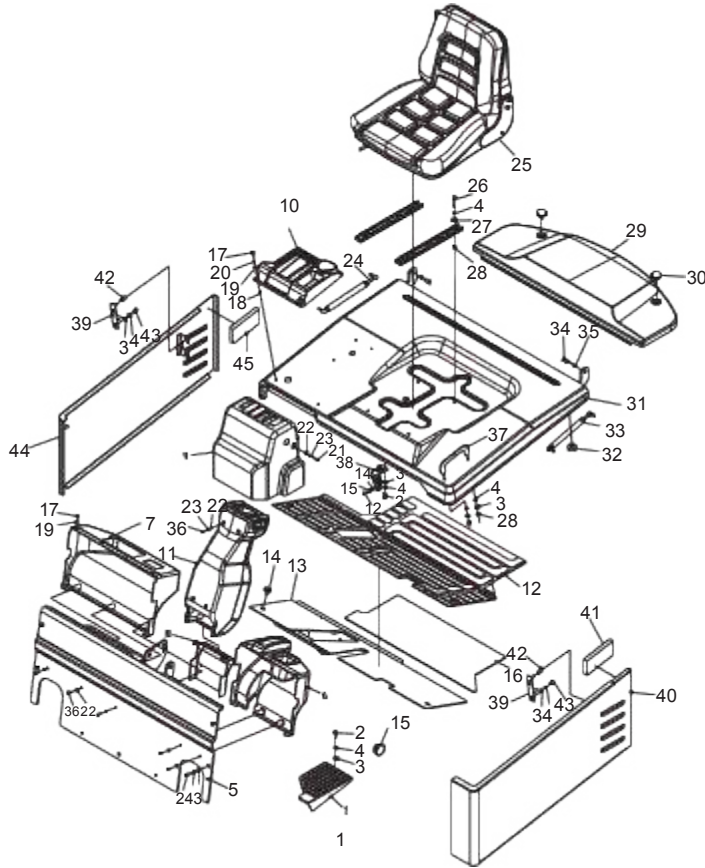

Item No	Code	Part No	Description	Q'ty	Remark
43	51204090914	GB/T5783	Bolt M8×16	6	
44	30009045712	E0015T.09.05.01	Side board weldment	1	
45	60700002764	E0025T.09.05-001	Seal stripe	1	



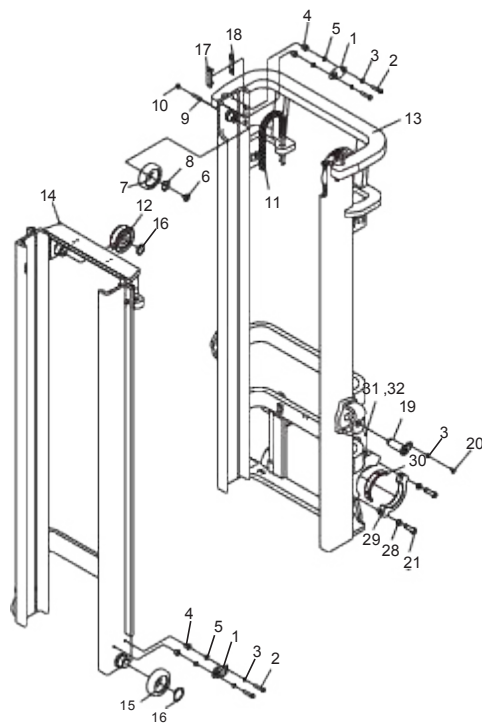

Item No	Code	Part No	Description	Q'ty	Remark
1	30080141002	E0016BE.10B.01.08	Roller	4	
2	51207105414	GB/T5786	Bolt M10×1.25×40	8	
3	51401100107	GB/T93	Washer 10	10	
4	60700002663	E0025T.10-002	Washer	8	
5	30080154802	E0015BJCL.10-009	Adjustment gasket	16	
6	30082153000	E0035DIII.10-001	Limit stopper	2	
7	30086141006	E0045D.10.09-001	Roller	2	
8	51453270107	GB/T894.1	Snap ring	2	
9	51106222507	GB/T77	Screw M10×45	2	
10	51307001019	GB/T6170	Nut M10	4	
11	30080080156	E0016BC.10B	LH1223 (99 C) chain assy. LH1234(101 )	2	
12	30080185701	E0015BJCL.10-001	Chain wheel	2	
14	30080082650	E0015T.10.01	Outer mast weldment	1	
15	30080081856	E0015T.10.02	Inner mast weldment	1	
13	30080141003	E0015BJCL.10-003	Roller	2	
16	51453350107	GB/T894.1	Snap ring	2	
17	30082185105	E0035DTN.10-004	Slide block	2	
18	60700002658	E0035DTN.10-005	Adjustment gasket	2	

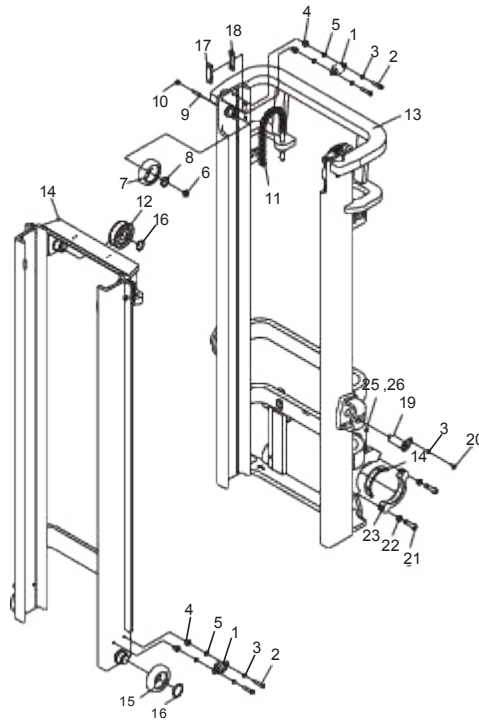

Item No	Code	Part No	Description	Q'ty	Remark
	60700002657	E0035DTN.10-005	Adjustment gasket		t=0.5mm
	6070000269	E0035DTN.10-005	Adjustment gasket		t=2.0mm
19	60700002906	E0015T.10.10	Pin shaft weldment	2	
20	51207105014	GB/T5786	Bolt M10×1.25×20	2	
21	51210120414	GB/T5785	Bolt M14×1.5×60	4	
22	51401120107	GB/T93	Washer 14	4	
23	60700002890	E0015T.10-002	End cover	2	
24	60700002891	E0015T.10-003	Bushing	2	
25	56201000301	JB/T7940.1	Oil cup M10×1	2	
26	60980005823	E0030D.10-021	Red sheath	2	

## Mástil

Code	Lifting H	Inner mast	Outer mast	Code,chain	Chain,leaf	Remark
30080910032	2000	30080081853	30080082647	30080080137	75	
30080910033	2500	30080081854	30080082648	30080080122	89	
30080910034	2700	30080081855	30080082649	30080080149	93	
30080910035	3000	30080081856	30080082650	30080080156	99	
30080910036	3300	30080081857	30080082651	30080080128	107	
30080910037	3500	30080081858	30080082652	30080080150	113	
30080910038	3700	30080081859	30080082653	30080080151	119	
30080910039	4000	30080081860	30080082654	30080080108	127	
30080910040	4250	30080081861	30080082655	30080080163	135	
30080910041	4500	30080081862	30080082656	30080080159	141	
30080910042	4750	30080081863	30080082657	30080080164	147	
30080910043	5000	30080081864	30080082658	30080080165	155	
30080910044	5500	30080081865	30080082659	30080080166	169	
30080910045	6000	30080081866	30080082660	30080080167	183	

# 15/FIG . 15

## Soporte de horquilla y elevación (mástil normal)

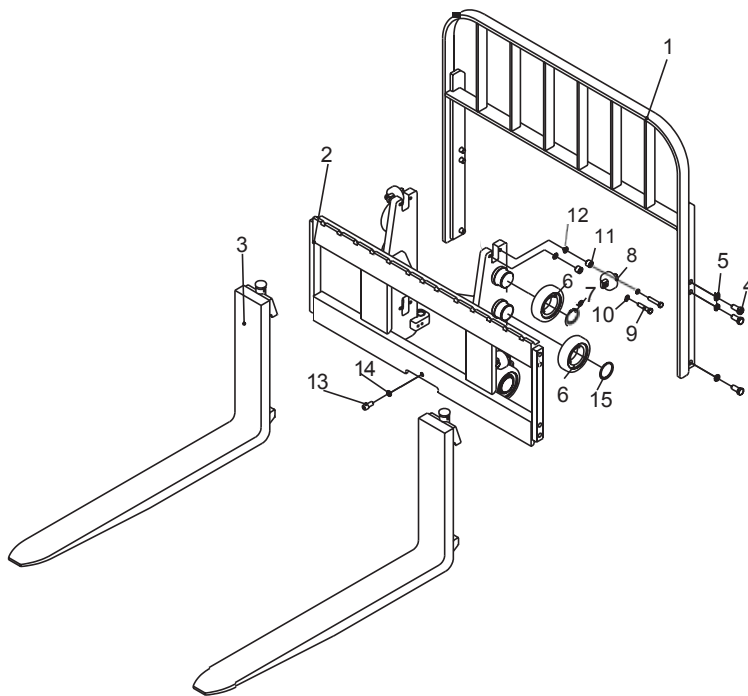

Item No	Code, fork	Model, fork	Remark
1	30080081200	120X35X920	
2	30080081201	120X35X1070	
3	30080081202	120X35X1220	
4	30080081203	120X35X1370	
5	30080081204	120X35X1520	
6	30080081205	120X35X1670	
7	30080081206	120X35X1820	
8	30080081207	120X35X1900	

# 15/FIG . 15

## Soporte de horquilla y elevación (mástil normal)

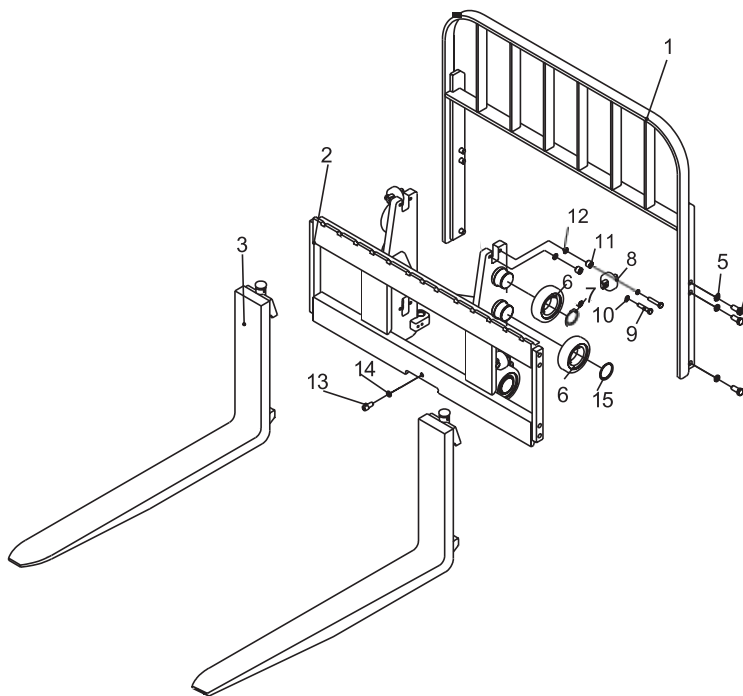

Item No	Code	Part No	Description	Q'ty	Remark
1	30080083524	E0015T.10.04	Load backrest weldment	1	
2	30080081026	E0015T.10.03	Fork carrier weldment	1	
3	30080081200	E0016BC.10.09	Fork assembly	2	
4	51207121214	GB/T5786	Bolt M14×1.5×30	8	
5	51401120107	GB/T93	Washer 14	8	
6	30080141003	E0015BJCL.10-003	Roller	6	
7	51453350107	GB/T894.1	Snap ring	4	
8	30080141004	E0025T.10.09	Roller assy.	4	
9	51207105518	GB/T5786	Bolt M10×1.25×45	8	
10	51401100107	GB/T93	Washer 10	8	
11	30086106400	E0060DT.10-007	Washer	8	
12	30080154802	E0015BJCL.10-009	Adjustment gasket	8	
13	51139230105	GB/T70.1	Screw M12×45	1	
14	51401110107	GB/T93	Washer 12	1	
15	60700002889	E0015T.10-001	Adjustment gasket	6	

# 16/FIG . 16

# Cilindro de elevación (normal)

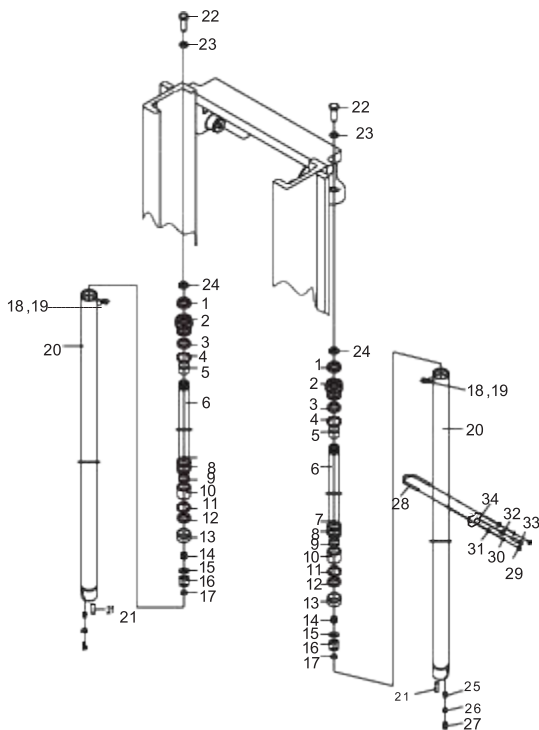

Item No	Code	Part No	Description	Q'ty	Remark
A	16600163810	LGG015SP300H.A	Lift cylinder	2	
1	56003101713		Wipers	2	
2	36600031270	LGG015SP300H.A-02	Guide sleeve	2	
3	56187032401		IDI-ring d40	2	
4	56908006904	AS568	O-ring	2	
5	52500010901		Bushing	2	
6	36600883930	LGG015SP300H.A-01	Rod	2	
7	51466240119	GB/T895.1	Snap ring 25	2	
8	36600021340	LGG015SP300H.A-03	Piston	2	
9	56145009204	GB/T3452.1	O-ring	2	
10	36600070780	LGG016SP400H-04	Spacer	2	
11	56192069201		Ring	2	
12	56191008601		U-ring D50	2	
13	56199002101		Wearing	2	
14	36600790200	LGG020SE300H.10	Check valve body	2	
15	51421120115	GB/T97.1	Snap ring 14	2	
16	36600060120	LGG015SP300H.A-04	Cushion collar	2	
17	51466240119	GB/T895.1	Snap ring 25	2	

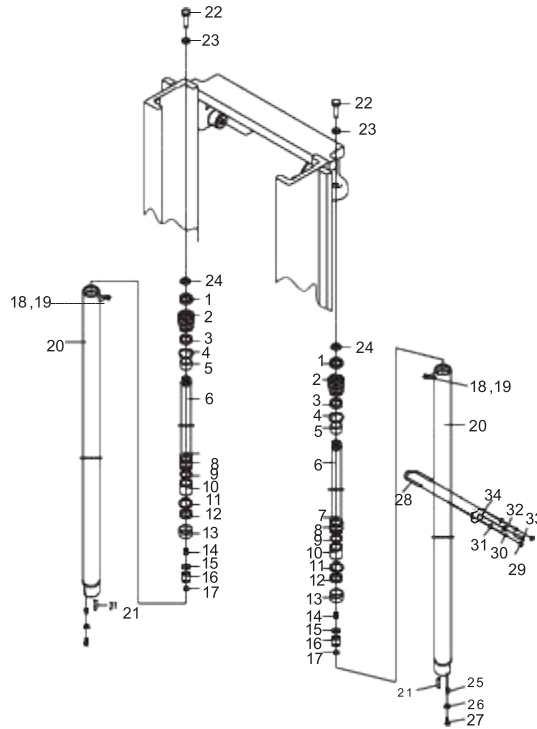

Item No	Code	Part No	Description	Q'ty	Remark
18	36600464630	LGG015SP300HA.01	Tube cylinder	2	
19	56147000101	JB/T982	Ring	2	
20	51139171506	GB/T70.1	Screw	2	
21	51513131502	GB/T119.1	Pin	2	
22	51204121614	GB/T5783	Bolt M14×50	2	
23	51401120107	GB/T93	Washer 14	2	
24	30080154803	E0016BC.10-010	Adjustment gasket	2	
25	51207115114	GB/T5786	bolt M12×1.25×25	2	
26	51401110107	GB/T93	Washer 12	2	
27	51421110115	GB/T97.1	Washer 12	2	
28	30080083400	E0015BJCL.10B.07	Clamp weldment	2	
29	51307000919	GB/T6170	Nut M8	4	
30	51401090107	GB/T93	Washer 8	4	
31	51421090115	GB/T97.1	Washer 8	4	
32	51307001019	GB/T6170	NutM10	2	
33	51204101514	GB/T5783	Bolt M10×45	2	
34	30080185601	E0015BJCL.10B-001	Clamp seat	2	

## Cilindro de elevación

Code	Lifting height	Postion rod	Cylinderbody	Remark
16600163780	2000	36600883900	36600464600	
16600163790	2500	36600883910	36600464610	
16600163800	2700	36600883920	36600464620	
16600163810	3000	36600883930	36600464630	
16600163820	3300	36600883940	36600464640	
16600163830	3500	36600883950	36600464650	
16600163840	3700	36600883960	36600464660	
16600163850	4000	36600883970	36600464670	
16600163860	4250	36600883980	36600464680	
16600163870	4500	36600883990	36600464690	
16600163880	4750	36600884000	36600464700	
16600163890	5000	36600884010	36600464710	
16600163900	5500	36600884020	36600464720	
16600163910	6000	36600884030	36600464730	



# 17/FIG . 17

# Cilindro de inclinación (normal)

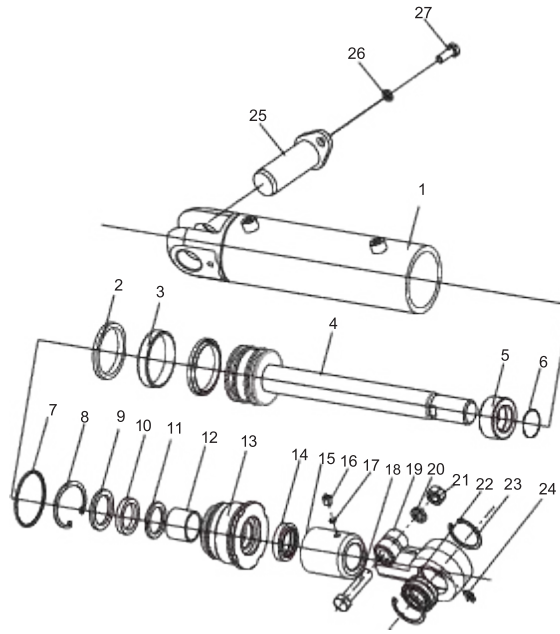

Cylinder code	Tilt angle	Spacer	Stop collar	Remark
16 600017310	6°-8°	---	---	
16 600017320	6°-6°	---	36600071 921	
16 600017330	3°-6°	36600071030	36600071 921	
16 600017340	3°-3°	36600071030	36600071 931	
16 600017350	6°-5°	---	36600071 941	
16 600017360	3°-5°	36600071030	36600071 941	

# 17/ FIG . 17

# Cilindro de inclinación (normal)

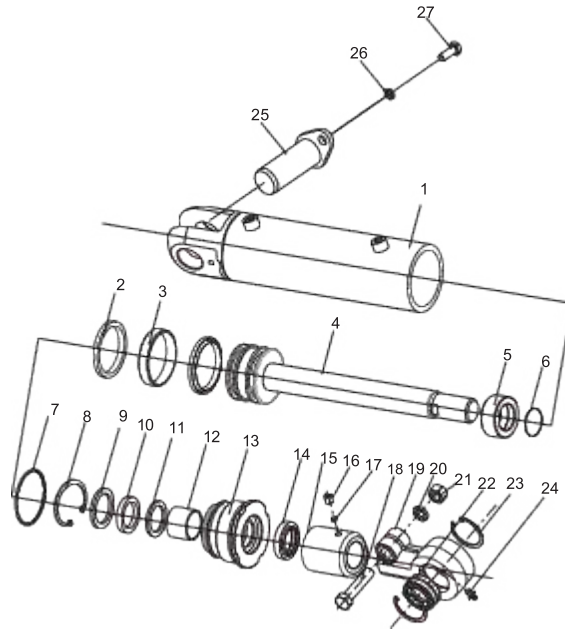

Item No	Code	Part No	Description	Q'ty	Remark
A	16600017310	LGG015X6/8H-W	Tilt cylinder	2	
1	36600464880	LGG015X6/8H-W.01	Tube cylinder	2	
2	56003212202		Wearing	4	
3	56003113410		seal ring	2	
4	36600884180	LGG015X6/8H-W.02	Rod body	2	
5	36600071030	LGG020X6/12H-05	Spacer	2	
6	56908004404	JISB2401	ring seal	2	
7	56194005301	EKM	O-ring seal	2	
8	51451360107	GB/T893.1	Ring 42	2	
9	36600310050	LGG015X6/8H-W-02	baffle	2	
10	56187019301		OSI-seal ring D30	2	
11	56192070301		Ring	2	
12	52500002201		Steel-backed bearing	2	
13	36600031290	LGG015X6/8H-W-01	Guide sleeve	2	
14	56003113513	Q/LG08002	Dustproof ring	2	
15	36600071910	LGG015X6/8H-W-03	S p a c e r	2	
16	36600321020	LGG030X6/12H-02	Lockout gasket	2	
17	51106221707	GB/T77	Screw	2	

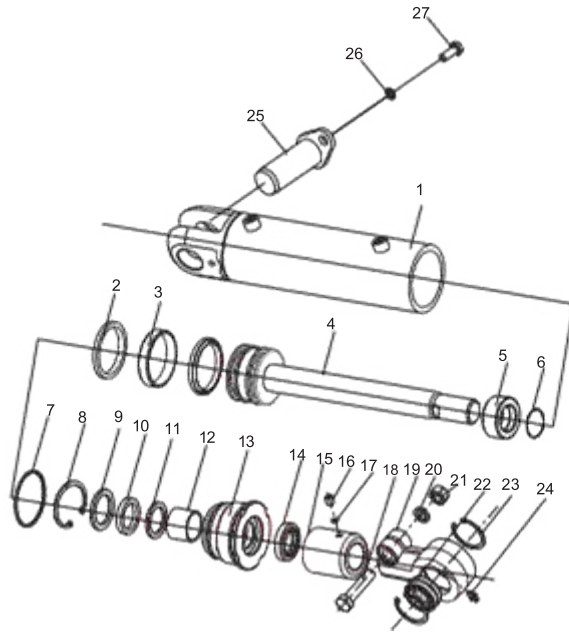

Item No	Code	Part No	Description	Q'ty	Remark
18	51210120314	GB/T5785	M14 × 1.5 × 55	Bolt	2
19	36600240120	LGG015X6/12H-01		Ear ring	2
20	51401120107	GB/T93	14	Washer	2
21	51309000619	GB/T6171	M14 × 1.5	Nut	2
22	52555000901	JB/T8879	GE30ES-C3	Joint bearing	2
23	51451380107	GB/T893.1	47	Snap ring 47	4
24	56201000501	JB/T7940.1	PT1/8	Oil cup	2
25	60700002903	E0015T.10.09		Pin shaft weldment	2
26	51207105014	GB/T5786	M10 × 1.25 × 20	Bolt	2
27	51401100107	GB/T93	10	Washer	2

# 18/FIG . 18

## Sistema de tubería de desplazamiento lateral (normal)

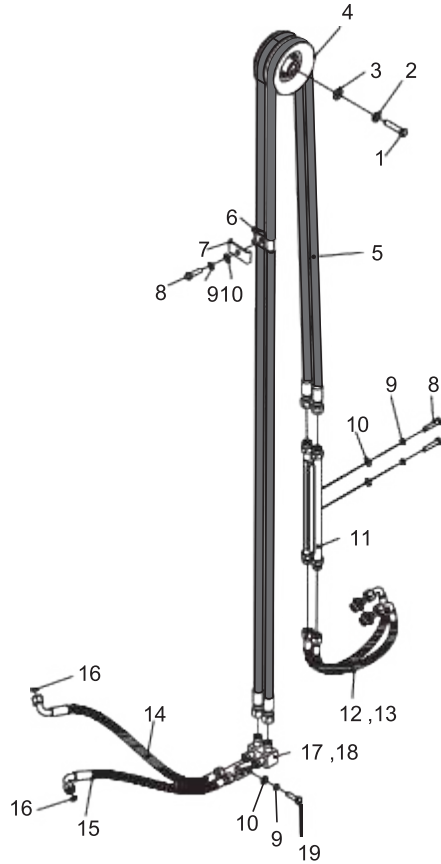

Lifting height	2000	2500	2700	3000	3300	3500	3700	4000
Hose_NO. 11	17272006923	17272009218	17272008728	17272009873	17272009273	17201000011	17272008734	17272009276
Lifting height	4250	4500	4750	5000	5500	6000		
Hose_NO. 11	17272009871	17201000013	17272009402	17272008580	17272009611	17272008584		

Item No	Code	Part No	Description	Q'ty	Remark
1	51210132414	GB/T5785	Bolt M16×1.5×90	1	
2	51401130107	GB/T93	Washer 16	1	
3	51421130115	GB/T97.1	Washer 16	1	
4	60700000379	E0030D.10.13-005	P u l l e y	1	
5	17272009873	E0025TBⅢ.10B.09.02	Hose assy.	2	
6	30012115000	E0030D.10.13-004	Bracket	1	
7	30082107802	E0030D.10.13-003	Clip	1	
8	51204091414	GB/T5783	Bolt M8×40	2	

# 18/FIG . 18

## Sistema de tubería de desplazamiento lateral (normal)

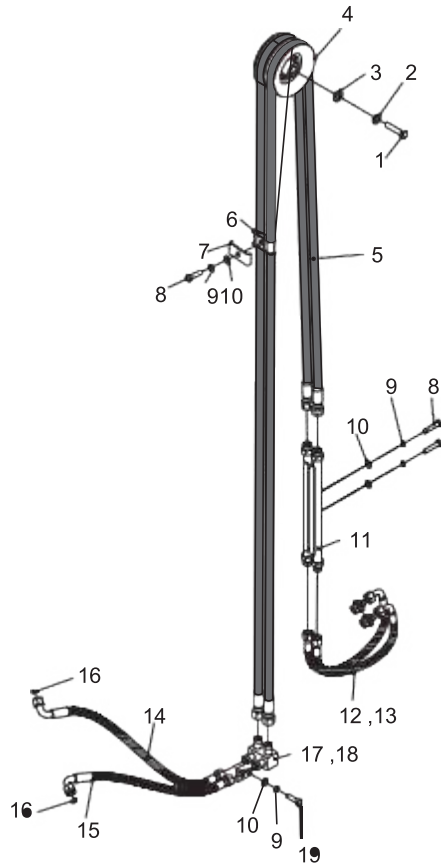

Item No	Code	Part No	Description	Q'ty	Remark
9	51401090107	GB/T93	Washer 8	4	
10	51421090115	GB/T97.1	Washer 8	4	
11	30082013340	E0030DIII.10.10.03	Steel tube assy.	1	
12	17272009684	20411-16T*1K05*1000	Hose assy.	2	
13	17272009225	20411-16T*1K05*1210	Hose assy.	2	
14	17272005350	E0025TD.10.08.03	Hose assy.	1	
15	17272008103	E0025TD.10.08.12	Hose assy.	1	
16	56145077501	GB/T3452.1	O-ring 8×2.65	2	
17	30082071705	E0025TBIII.10.09.02	Connector weldment	1	
18	30082071706	E0025TBIII.10.09.03	Connector weldment	1	
19	51204091014	GB/T5783	Bolt M8×20	2	

# 19/FIG . 19

## Sistema de tubería de elevación (mástil normal)

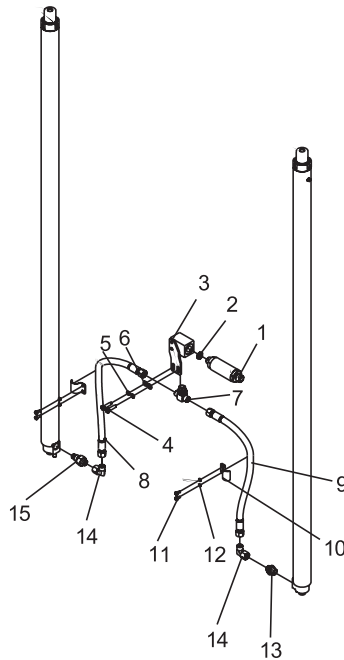

Item No	Code	Part No	Description	Q'ty	Remark
1	60300000465	E0015TBJCL.12.09	Limit speed valve	1	
2	56905000904	ISO	O-ring 19.3×2.4	1	
3	60700002897	E0015T.10.06.01	T-connector	1	
4	51204091214	GB/T5783	Bolt M8×30	2	
5	51401090107	GB/T93	Washer 8	2	
6	51421090115	GB/T97.1	Washer 8	2	
7	60700002901	E0015T.10.06.02	T-connetor	1	
8	17272015701	E0015T.10.06-003	Hose assy.	1	
9	17272015700	E0015T.10.06-002	Hose assy.	1	
10	60700002896	E0015T.10.06-001	Clip	2	
11	51204080814	GB/T5783	Bolt M6×12	4	
12	51401080107	GB/T93	Washer 6	4	
13	17601000221	L1CH-18-20	Transition connector	1	
14	17601000601	L2C9-18W	Transition connector	2	
15	60300000464	E0015TBJCL.12.07.02	Cutoff valve assy.	1	

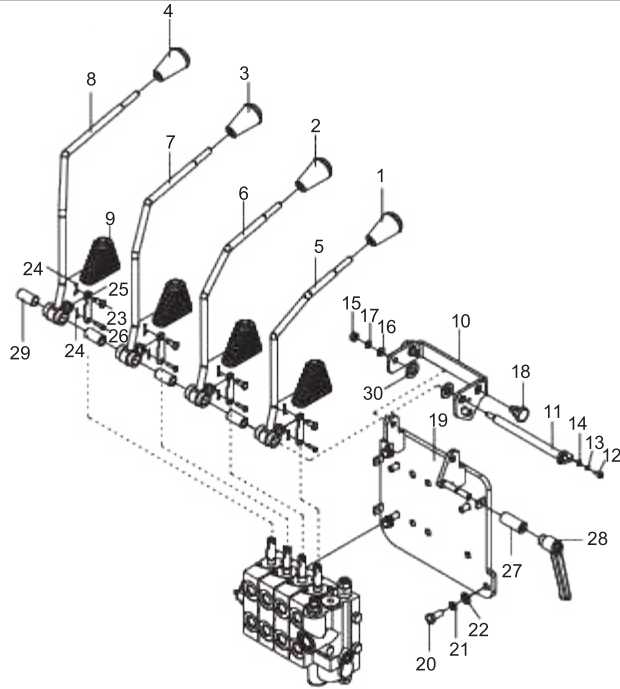

Item No	Code	Part No	Description	Q'ty	Remark
1	60207010080	30D-1100001	Handle assembly	1	
2	60207010081	30D-1100002	Handle assembly	1	
3	60207010082	E0030D.11-003	Handle assembly	1	
4	60207010083	E0030D.11-004	Handle assembly	1	
5	60700002697	E0025T.11.01	Control lever weldment	1	
6	60700002698	E0025T.11.02	Control lever weldment	1	
7	60700002699	E0025T.11.03	Control lever weldment	1	
8	60700002700	E0025T.11.04	Control lever weldment	1	
9	60700002702	E0025T.11-001	Dust sleeve	2	
10	30011115016	E0025T.11-002	Bracket	1	
11	30011025003	E0025T.11.05	Pin shaft weldment	1	
12	51158190304	GB/T818	Screw M6×12	1	
13	51421080115	GB/T97.1	Washer 6	1	
14	51401080107	GB/T93	Washer 6	1	
15	51307000919	GB/T6170	Nut M8	1	
16	51421090115	GB/T97.1	Washer 8	1	
17	51401090107	GB/T93	Washer 8	1	
18	30003111107	20B-0300003	Bolt	2	

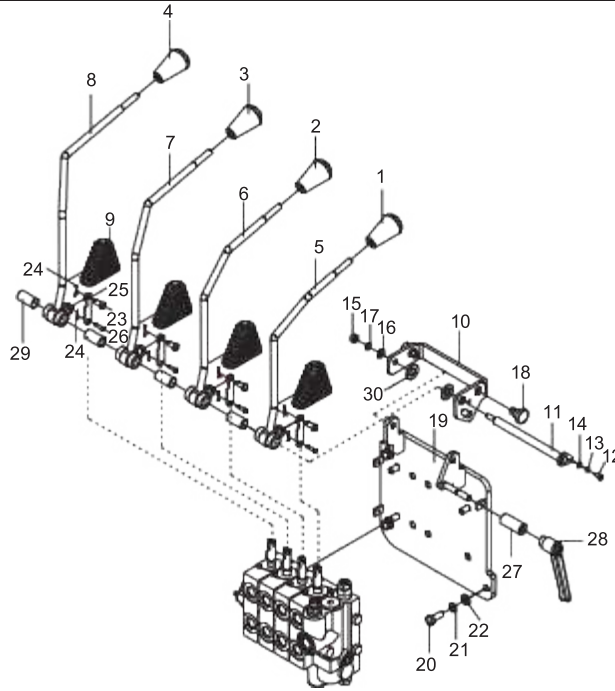

Item No	Code	Part No	Description	Q'ty	Remark
19	30011040104	E0025T.11.06	Fixed board weldment	1	
20	51204101314	GB/T5783	Bolt M10×35	3	
21	51401100107	GB/T93	Washer 10	3	
22	51421100115	GB/T97.1	Washer 10	3	
23	51511050702	GB/T882	Pin B8×18	2	
24	51512060801	GB/T91	Pin 2×16	4	
25	30011117511	E0025T.11-003	Connecting rod	2	
26	60905000023	30D-1100004	Pin shaft	2	
27	30011135100	E0025T.11-004	Shaft sleeve	1	
28	60700002705	E0025T.03.03	Lock handle assy.	1	
29	30011135104	E0025T.11-005	Shaft sleeve	2	
30	30003106412	E0025T.11-006	Washer	2	



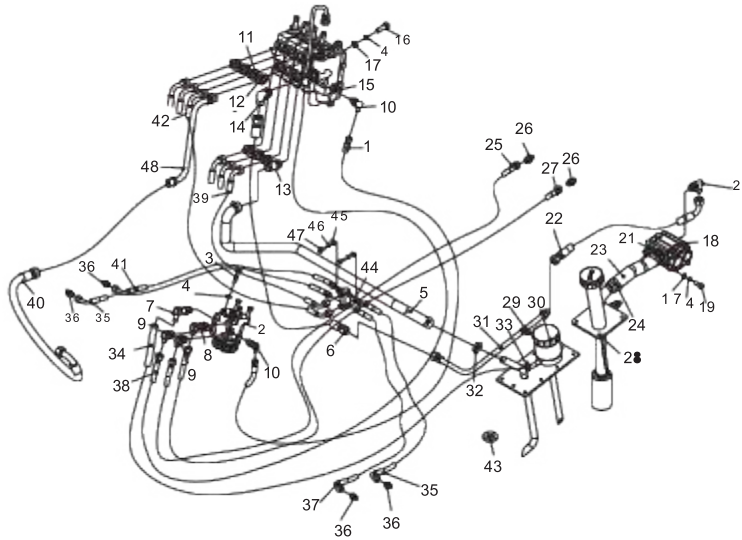

Item No	Code	Part No	Description	Q'ty	Remark
1	17272015689	E0015T.12.01	Hose assy.	1	
2	60300003771	E0015T.12.02	Steering gear	1	
3	51204101514	GB/T5783	Bolt M10×45	4	
4	51401100107	GB/T93	Washer 10	10	
5	60700002927	E0015T.12-001	Oil return pipe	1	
6	17272015690	E0015T.12.03	Hose assy.	1	
7	60700002674	E0025T.12.05	Transition connector	1	
8	60700002675	E0025T.12.06	Transition connector	2	
9	60700002676	E0025T.12.07	Transition connector	2	
10	17601000019	L1CH9-14-12OG	Transition connector	2	
11	17601000212	30D-1200001	Transition connector	2	
12	17601000239	E0030B.12.12	Transition connector	1	
13	60700002678	E0025T.12.09	Transition connector	1	
14	17601000300	30D-1215000	Multiway valve assy.	1	
15	60300003767	E0015T.12.04	Bolt M10×1.25×30	1	
16	51207105214	GB/T5786	Washer 10	4	
17	51421100115	GB/T97.1	Gear pump	6	
18	60300003733	E0025T.12.11	Bolt M10×30	1	

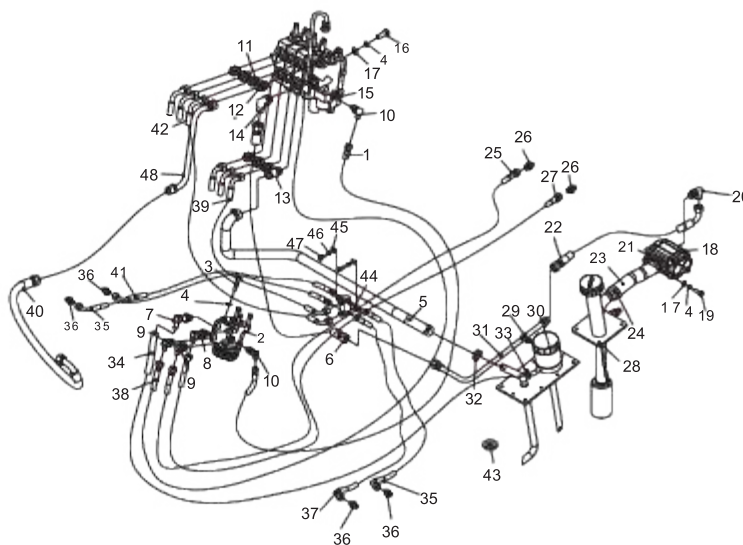

Item No	Code	Part No	Description	Q'ty	Remark
19	51204101214	GB/T5783	Transition connector	2	
20	17601000189	E0016BE.12.06	Transition connector	1	
21	32012108303	E0020DR.12-005	Hose assy.	1	
22	17272015691	E0015T.12.05	OilSuction pipe	1	
23	60700002929	E0015T.12-002	Hoop d50(32~50)	1	
24	56171000601	JB/T8870	Hose assy.	2	
25	17272015692	E0015T.12.06	Transition connector	1	
26	17601000007	30D-1200027	Hose assy.	2	
27	17272015693	E0015T.12.07	Cover plate assy.	1	
28	30012073031	E0015T.12.08	Wire clip	1	
29	60700000357	E0030DTXBIII.09CE-001	Cover plate assy.	1	
30	30012073032	E0015T.12.09	Steel tube assy.	1	
31	60700002925	E0015T.12.10	Hoop d25(16~25)	1	
32	56171000301	JB/T8870	Hoop d32(20~32)	2	
33	56171002301	JB/T8870	HoseΦ13×4-L=1350	2	
34	30012187922	E0030D.12.10-003	Hose assy.	1	
35	17272015694	E0015T.12.11	Transition connector	2	
36	30088108301	LG0100DTIII.10G.05.06	Transition connector	4	

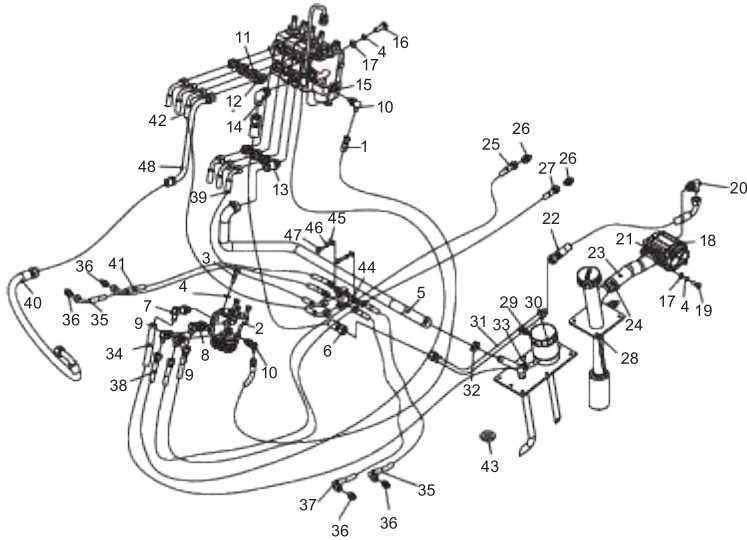

Item No	Code	Part No	Description	Q'ty	Remark
37	17272015695	E0015T.12.12	Hose assy.	1	
38	17272015696	E0015T.12.13	Hose assy.	1	
39	17272015697	E0015T.12.14	Hose assy.	1	
40	17272015698	E0015T.12.15	Hose assy.	1	
41	17272015675	E0025T.12.20	Hose assy.	1	
42	17272015699	E0015T.12.16	Hose assy.	1	
43	60980000538	20B-1206005	Magnet50×25×8	3	
44	60300003768	E0015T.12.17	Distribution block	1	
45	51401090107	GB/T93	W a s h e r 8	5	
46	51421090115	GB/T97.1	Washer 8	5	
47	51204090914	GB/T5783	Bolt M8×16	2	
48	60700002926	E0015T.12.18	Steel tube assy.	1	

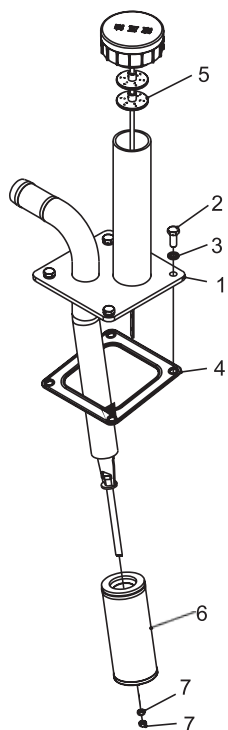

Item No	Code	Part No	Description	Q'ty	Remark
1	60700002932	E0015T.12.08.01	Cover plate weldment	1	
2	51204091014	GB/T5783	Bolt M8×20	4	
3	56147012401	JB/T982	Washer 8	4	
4	60300003738	E0025T.12.17-001	W a s h e r 8	1	
5	60300003770	E0015T.12.08.02	Oil dipstick assy.	1	
6	60300003736	E0025T.12.17.03	Filter element	1	
7	51307000919	GB/T6170	Nut M8	2	

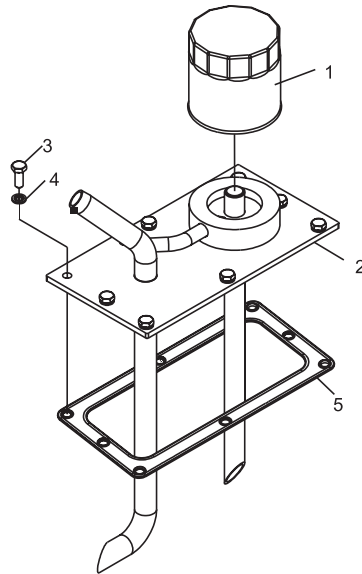

Item No	Code	Part No	Description	Q'ty	Remark
1	60300003737	E0025T.12.18.01	Oil filter	1	
2	60700002933	E0015T.12.09.01	Cover plate weldment	1	
3	51204091014	GB/T5783	Bolt M8×20	8	
4	56147012401	JB/T982	Combination washer	8	
5	60700002928	E0015T.12.09-001	Seal gasket	1	

# 24/FIG .24

# Guardia superior

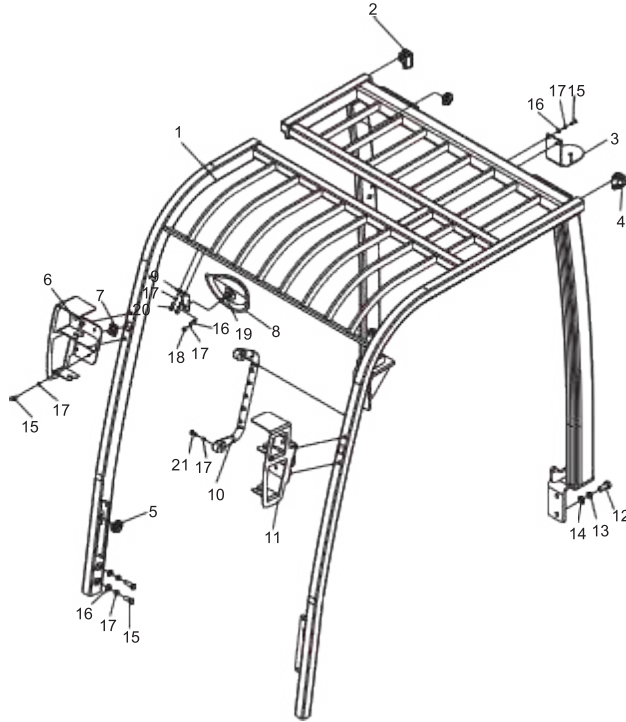

Item No	Code	Part No	Description	Q'ty	Remark
1	30014058587	E0015T.14.01	Overhead guard weldment	1	
2	60700002734	E0025T.14-007	Hood	1	
3	30014114917	E0025T.14-001	Bracket	1	
4	60700002735	E0025T.14-008	Hood	1	
5	60400002555	E0035DTN.15-001	Rubber ring	6	
6	30014114918	E0025T.14-002	Bracket	1	
7	60700002729	E0025T.14-006	Rubber ring	2	
8	60700001522	E0030DIII.09.06	Backup mirror	1	
9	30014114919	E0025T.14-003	Bracket	1	
10	60700002717	E0025T.14-005	Handle	1	
11	30014114920	E0025T.14-004	Bracket	1	
12	51204111318	GB/T5783	Bolt M12×35	8	
13	51401110107	GB/T93	Washer 12	8	
14	51421110115	GB/T97.1	Washer 12	8	
15	51204091014	GB/T5783	Bolt M8×20	10	
16	51421090115	GB/T97.1	Washer 8	7	
17	51401090107	GB/T93	Washer 8	15	
18	51307000919	GB/T6170	Nut M8	1	

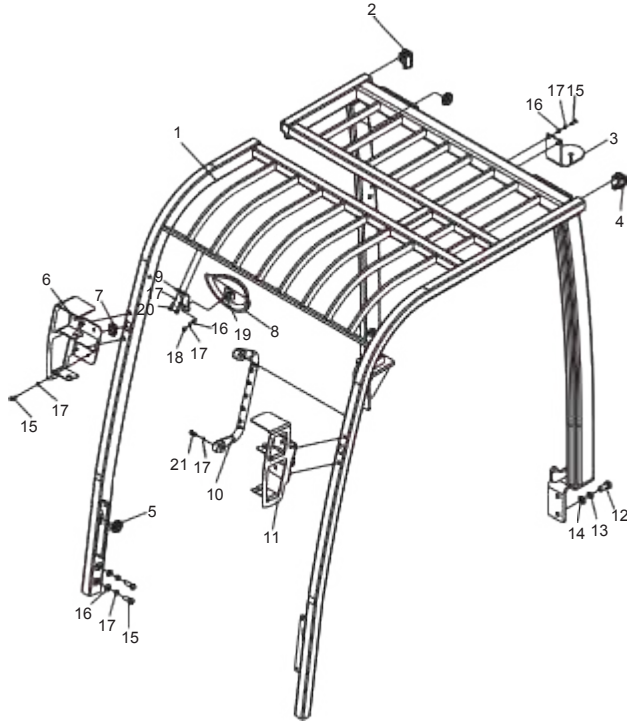

Item No	Code	Part No	Description	Q'ty	Remark
19	30001115135	E0030DIII.09-038	Bracket	1	
20	51158210404	GB/T818	Screw M8×16	2	
21	51139210505	GB/T70.1	Screw M8×25	2	

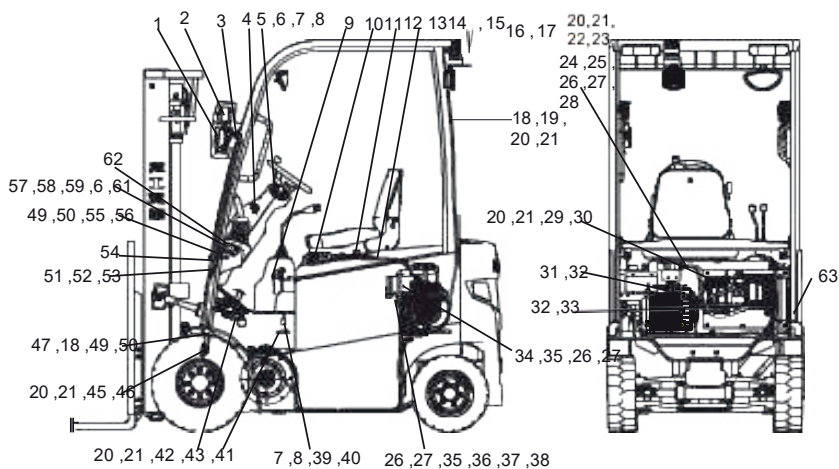

Item No	Code	Part No	Description	Q'ty	Remark
1	60400002726	E0025T.15.01	Working lamp	2	
2	60400002745	E0025T.15.02	Front combination lamp	2	
3	60400002714	E0025T.15.03	Lamp harness	2	
4	60400002752	E0025T.15.04	Key switch	1	
5	60400002756	E0025T.15.05	Combination switch	1	
6	51158170904	GB/T818	Screw M5×30	4	
7	51421070115	GB/T97.1	Washer 5	6	
8	51401070107	GB/T93	Washer 5	6	
9	30015162322	E0025T.15.06	Multiway valve switch	2	
10	60400002710	E0025T.15.07	USB charger	1	
11	60405020207	E0016B.15.20	Emergency stop switch	1	
12	60980005598	E0030DIII.15-003	Binding tape	10	
13	60400002736	E0025T.15.08	Warning lamp harness	1	
14	60400002730	E0025T.15.09	Rear combination lamp	2	
15	60400002850	E0025TBJVI.15-001	Rubber gasket	2	
16	60400002735	E0025T.15.10	Warning lamp	1	
17	60400002891	E0025T.15.28	Sound & light alarm lamp	1	
18	60400002729	E0025T.15.11	Rear handle assy.	1	



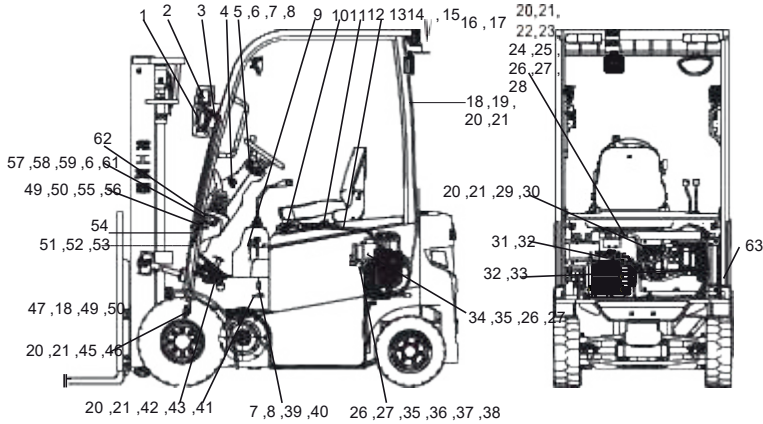

Item No	Code	Part No	Description	Q'ty	Remark
19	51139210505	GB/T70.1	Screw M8×25	2	
20	51421090115	GB/T97.1	Washer 8	15	
21	51401090107	GB/T93	W a s h e r 8	15	
22	60400002790	E0015T.15.01	Connector plug	1	
23	60400002986	E0015T.15.10	Connector plug	1	
24	30015115078	E0015T.15-001	Bracket	1	
25	51158191204	GB/T818	Screw M6×50	4	
26	51421080115	GB/T97.1	Washer 6	12	
27	51401080107	GB/T93	Washer 6	12	
28	51204091014	GB/T5783	Bolt M8×20	4	
29	60400002793	E0015T.15.02	Electrical control assy.	1	
30	51204091614	GB/T5783	Bolt M8×50	4	
31	60400002796	E0015T.15.03	Pump motor cable	1	
32	60400002799	E0015T.15.04	Magnetic ring	12	
33	60400002800	E0015T.15.05	Traction motor cable	1	
34	60400002708	E0025T.15.19	DC converter	1	
35	51158190504	GB/T818	Screw M6×16	8	
36	60400002711	E0025T.15.20	Fuse box assy.	1	

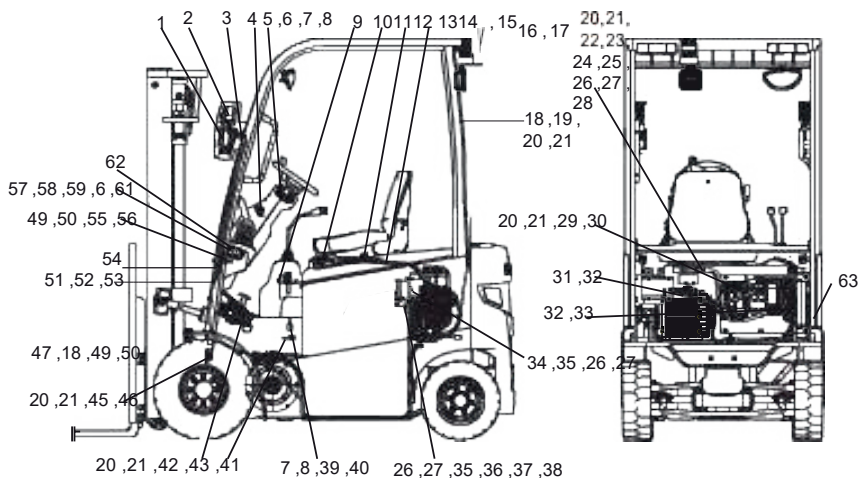

Item No	Code	Part No	Description	Q'ty	Remark
37	60402050036	20B-1518000	Flasher	1	
38	60400000341	E0030D.15A-007	Backup buzzer	1	
39	60400002987	E0015T.15.11	Potentiometer	1	
40	51139170305	GB/T70.1	Screw M5×12	2	
41	60400000343	E0016B.15A.08	Brake lamp switch	1	
42	60400002733	E0025T.15.21	Accelerating pedal	1	
43	51204091114	GB/T5783	Bolt M8×25	2	
44	51307000919	GB/T6170	Nut M8	2	
45	60400002738	E0025T.15.22	Horn	1	
46	51204090914	GB/T5783	Bolt M8×16	1	
47	60400002739	E0025T.15.23	Horn wave filter	1	
48	51158140304	GB/T818	Screw M4×8	2	
49	51421060115	GB/T97.1	Washer 4	4	
50	51401060107	GB/T93	Washer 4	4	
51	60400002804	E0015T.15.07	Wire harness assy	1	
52	30015880102	E0015T.15.08	Electrical schematic diagram	1	
53	30015880119	E0015T.15.09	Electrical schematic diagram	1	
54	60980000547	30D-1500001	Binding tape	15	

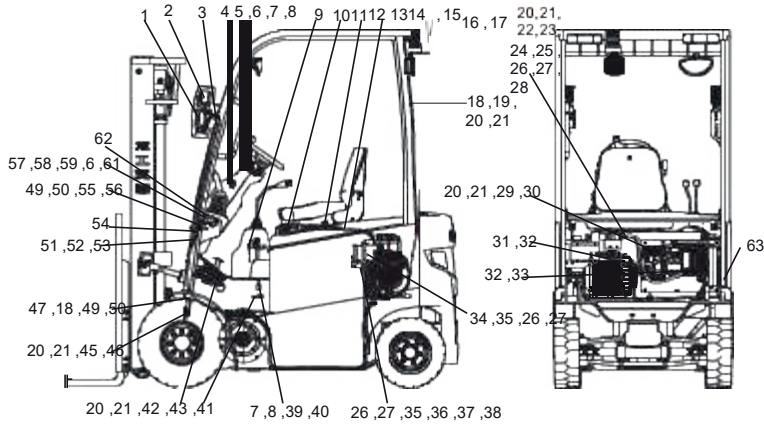

Item No	Code	Part No	Description	Q'ty	Remark
55	60400002571	E0035DTN.15.24	Inching switch	1	
56	51158140804	GB/T818	Screw M4×20	2	
57	30015161500	E0075DTG.15.19	Panel swich	1	
58	60400002569	E0035DTN.15.18	P a n e l s w i c h	1	
59	60400002892	E0025T.15.29	Connecting harness	1	
60	60400002568	E0035DTN.15.17	P a n e l s w i c h	1	
61	60400002893	E0025T.15.30	Connecting harness	1	
62	60400002862	E0025T.15.26	Instrument	1	
63	30015162323	E0025T.15.27	Side pull switch	1	

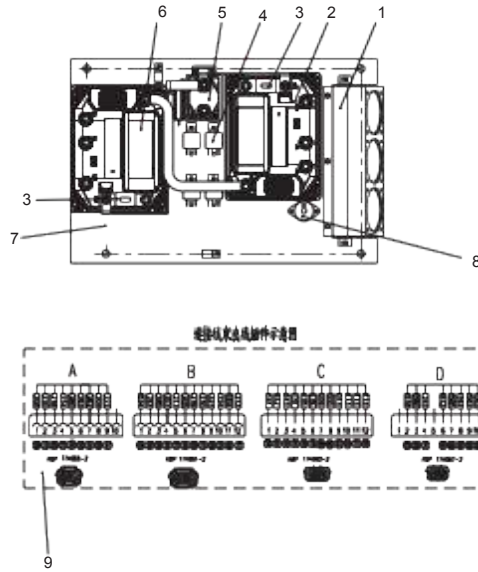

Item No	Code	Part No	Description	Q'ty	Remark
1	60400002794	E0015T.15.02.01	Fan assy.	1	
2	60400002786	ACS48S+450C-35P	Traction controller	1	
3	60400002749	250A	Fuse and seat	2	
4	60400002732	HFV4-1Z6G-DC12V	Relay	4	
5	60400002755	SW200-262	Main contactor	1	
6	60400002712	ACS48S-350C-23P	Pump controller	1	
7	60400002795	E0015T.15.02.02	Bottom plate of cooler	1	
8	60400002724	E0025T.15.14.02	Electrical buzzer	1	
9	60400008007	E0015T.15.02.03	Electrical wire harness	1	

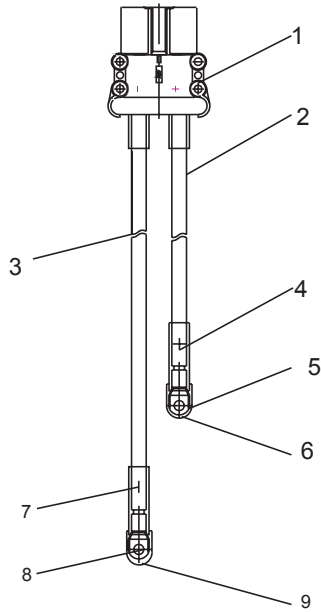

Item No	Code	Part No	Description	Q'ty	Remark
1	60400002990	95044-01	Electrical connector plug	1	REMA160
2	60400002992	TVR-105 1X50 B	Positive polar wire	1	600mm
3	60400002993	TVR-105 1X50 B	Negative polar wire	1	700mm
4	60400002791	E0015T.15.01.01	Thermal shrinkage pipe	1	
5	60400002599	JG50	Wire connecting terminal	1	50-10
6	60400002989	E0015T.15.01.03	Red rubber cap	1	
7	60400002792	E0015T.15.01.02	Thermal shrinkage pipe	1	
8	60400002598	JG50	Wire connecting terminal	1	50-8
9	60400002988	E0015T.15.01.04	Black rubber cap	1	

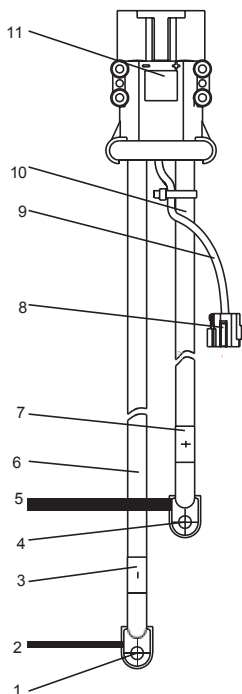

Item No	Code	Part No	Description	Q'ty	Remark
1	60400002598	Jg50	Wire connecting terminal	1	Aug-50
2	60400002988	E0015T.15.01.04	Black rubber cap	1	
3	60400002792	E0015T.15.01.02	Thermal shrinkage pipe	1	
4	60400002599	JG50	Wire connecting terminal	1	Oct-50
5	60400002989	E0015T.15.01.03	Red rubber cap	1	
6	60400002993	TVR-105 1X50 B	Negative polar wire	1	700mm
7	60400002791	E0015T.15.01.01	Thermal shrinkage pipe	1	
8	60700001575	174257-2	Communication interface sheath	1	AMP
9	60400002830	KVV 4x0.75	Communication cable	1	200mm
10	60400002992	TVR-105 1X50 B	Positive polar wire	1	600mm
	60400002979	95043-01	Electrical connector plug	1	REMA160

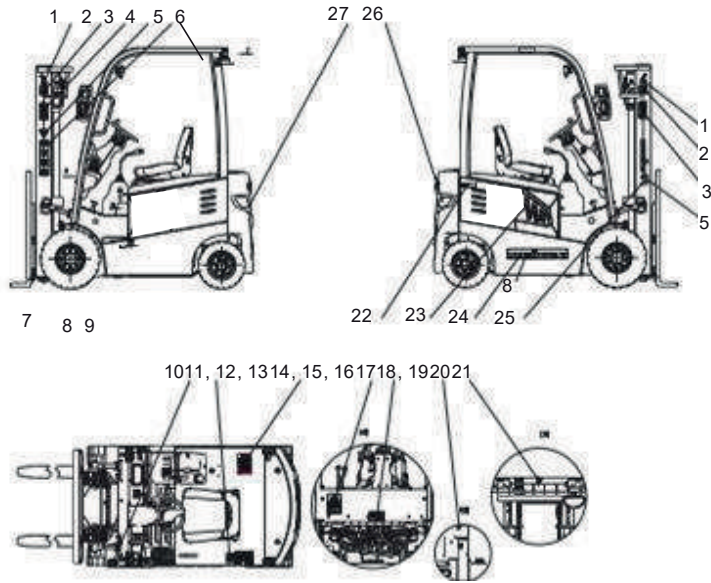

Item No	Code	Part No	Description	Q'ty	Remark
1	30016197803	E0030DIII.16-003	Hoistlabel	2	
2	30016197300	20B-1600001	No stay label	1	
3	30016198700	20B-1600019	C E l a b e l	2	
4	60700002009	20B-1600022	Oil paint label	1	
5	30016197517	30DII-1600001	Lonking label	2	
6	30016197101	E0030D.16-005	Hoistpointlabel	1	
7	30016198510	E0030DIII.16-006	Oillabel	1	
8	30016197518	30DII-1600002	Lonkinglabel	2	
9	30016198275	E0015TBJCL.16-001	Modellabel	1	
10	68000000662	E0015T.16-003	Tire pressure label	1	
11	68000000233		Two-dimensionalcode	1	
12	30016198000	20B-1600012	Noticelabel(Chinese)	1	
13	30016198002	20B-1600018	Noticelabel(English)	1	
14	30016197700	20B-1600017	Nameplate	1	
15	51569000106	GB/T12618.1	Mashroomblindedrivet4×12	8	
16	60700000838	E0050DTIV.16-009	load curve chart label	1	
17	68000000649	E0025T.16-001	Lubricantpointlabel	1	
18	30016197319	E0030DIII.16-013	Modellabel	1	

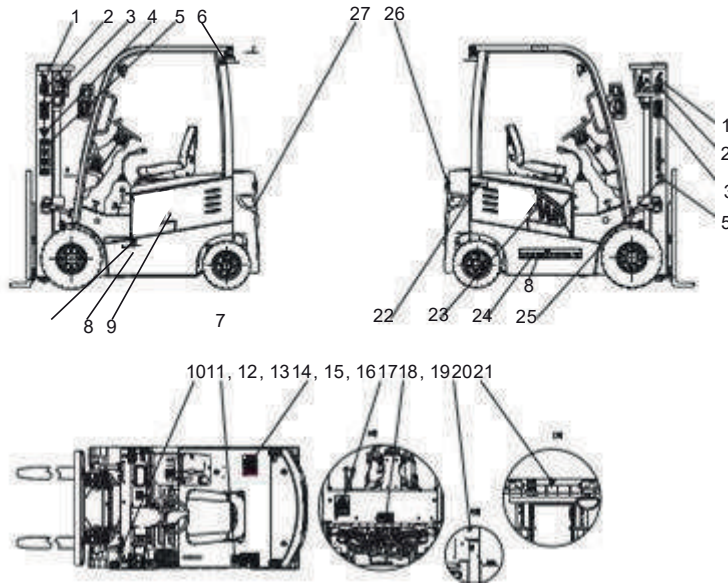

Item No	Code	Part No	Description	Q'ty	Remark
19	30016197301	20B-1600002	Do not enter back side of mast	1	
20	30016199300	E0025TBIII.16-002	Brake fluid label	1	
21	30016197315	E0030D.16-019	Do not lift	1	
22	30016197200	E0030B.16-011	AC sign	1	
23	30016198276	E0015TBJCL.16-002	Modellabel	1	
24	30016197507	E0030D.16-008	Lonkinglabel	2	
25	30016197506	E0030D.16-003	Lonkinglabel	2	
26	60700003316	E0015T.16-001	Glistensticker	1	
27	60700003317	E0015T.16-002	Glistensticker	1	



30/FIG .30

Conjunto de contrapeso

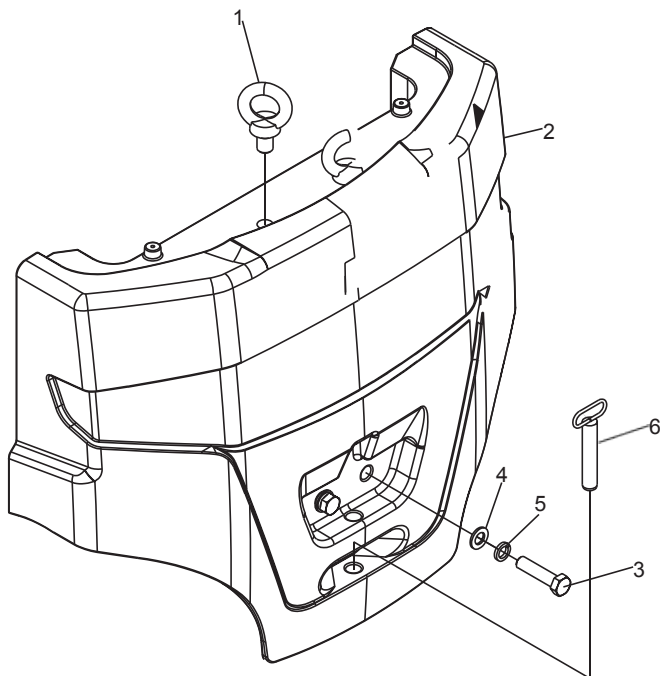

Item No	Code	Part No	Description	Q'ty	Remark
1	51142270208	GB/T825	Screw M24	2	
2	60600000535	E0015T.17-001	Counter weight	1	A
	60600000601	E0018BVI.17-001	Counter weight	1	B
3	51203172614	GB/T5782	Bolt M24×100	2	
4	33017106400	LG0260DT.08-012	Washer	2	
5	51401170107	GB/T93	Washer 24	2	
6	30017038512	E0025T.17.01	Traction pin weldment	1	